

**2003 Ford Explorer**

SYSTEM WIRING DIAGRAMS 'Ford - Explorer

**SYSTEM WIRING DIAGRAMS**

**Ford - Explorer**

**AIR CONDITIONING**

# 2003 Ford Explorer

## SYSTEM WIRING DIAGRAMS 'Ford - Explorer

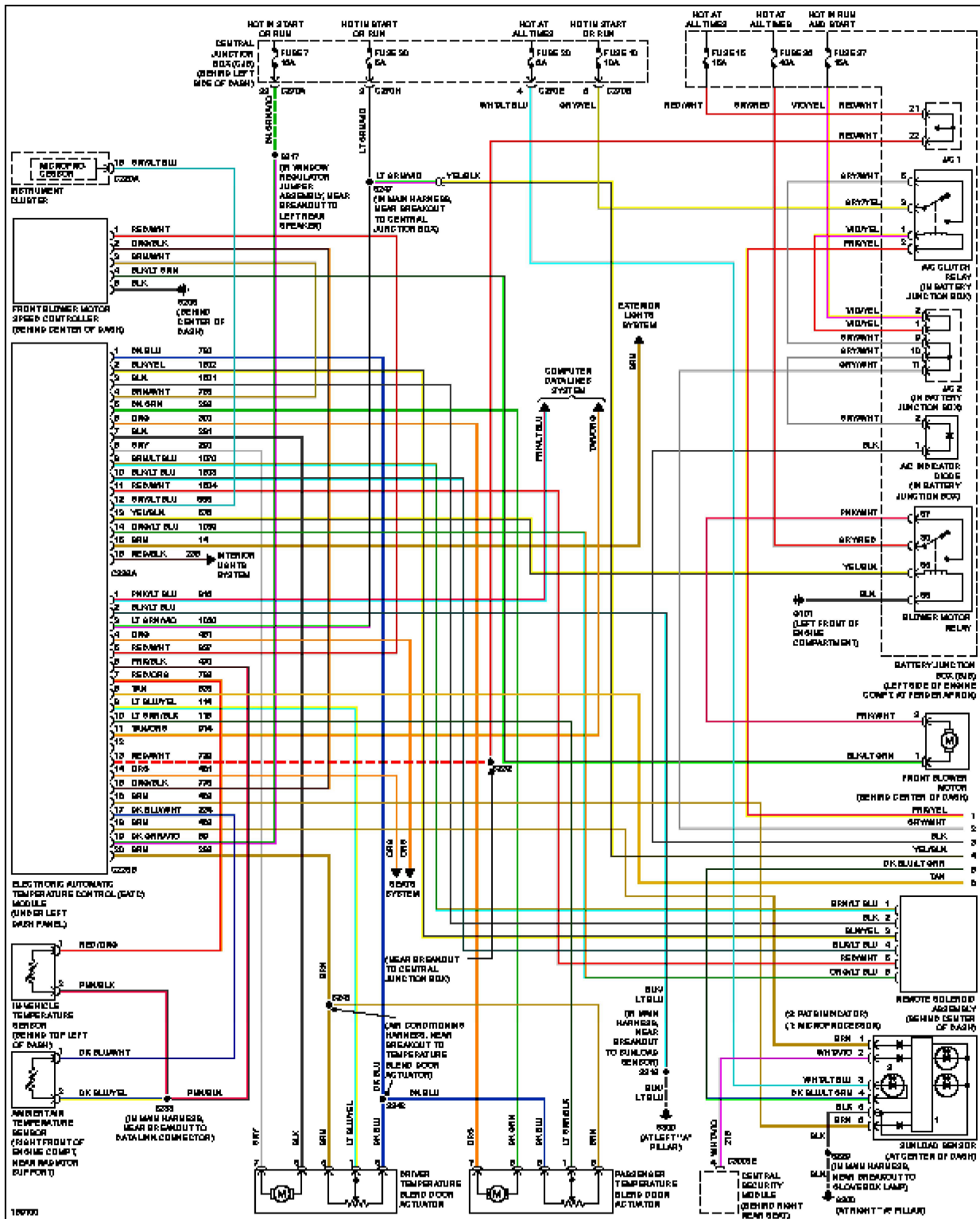
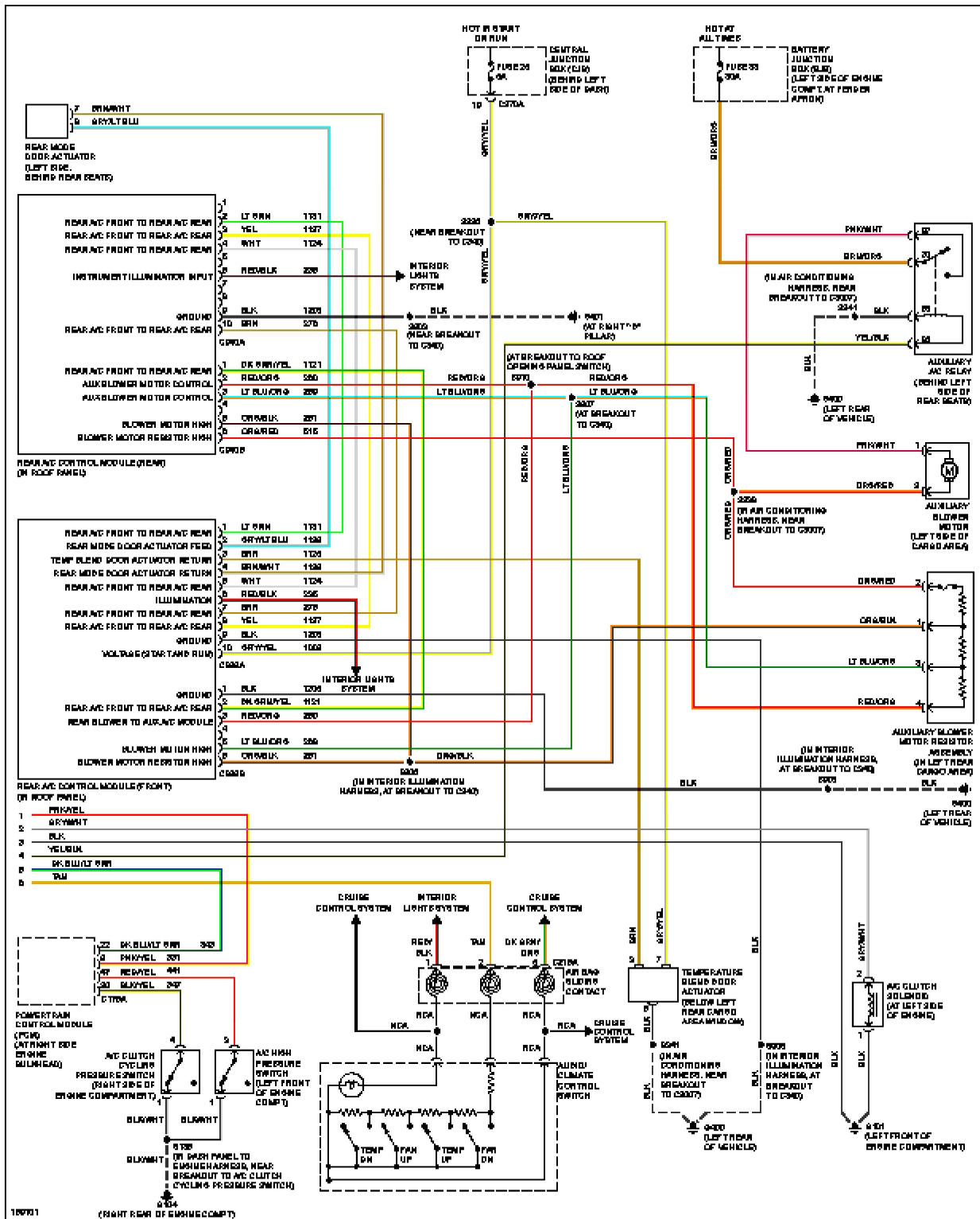

**Fig. 1: Automatic A/C Circuit (1 of 2)**



# 2003 Ford Explorer

## SYSTEM WIRING DIAGRAMS 'Ford - Explorer



Monday, March 04, 2019 7:57:35 AM

# 2003 Ford Explorer

## SYSTEM WIRING DIAGRAMS 'Ford - Explorer

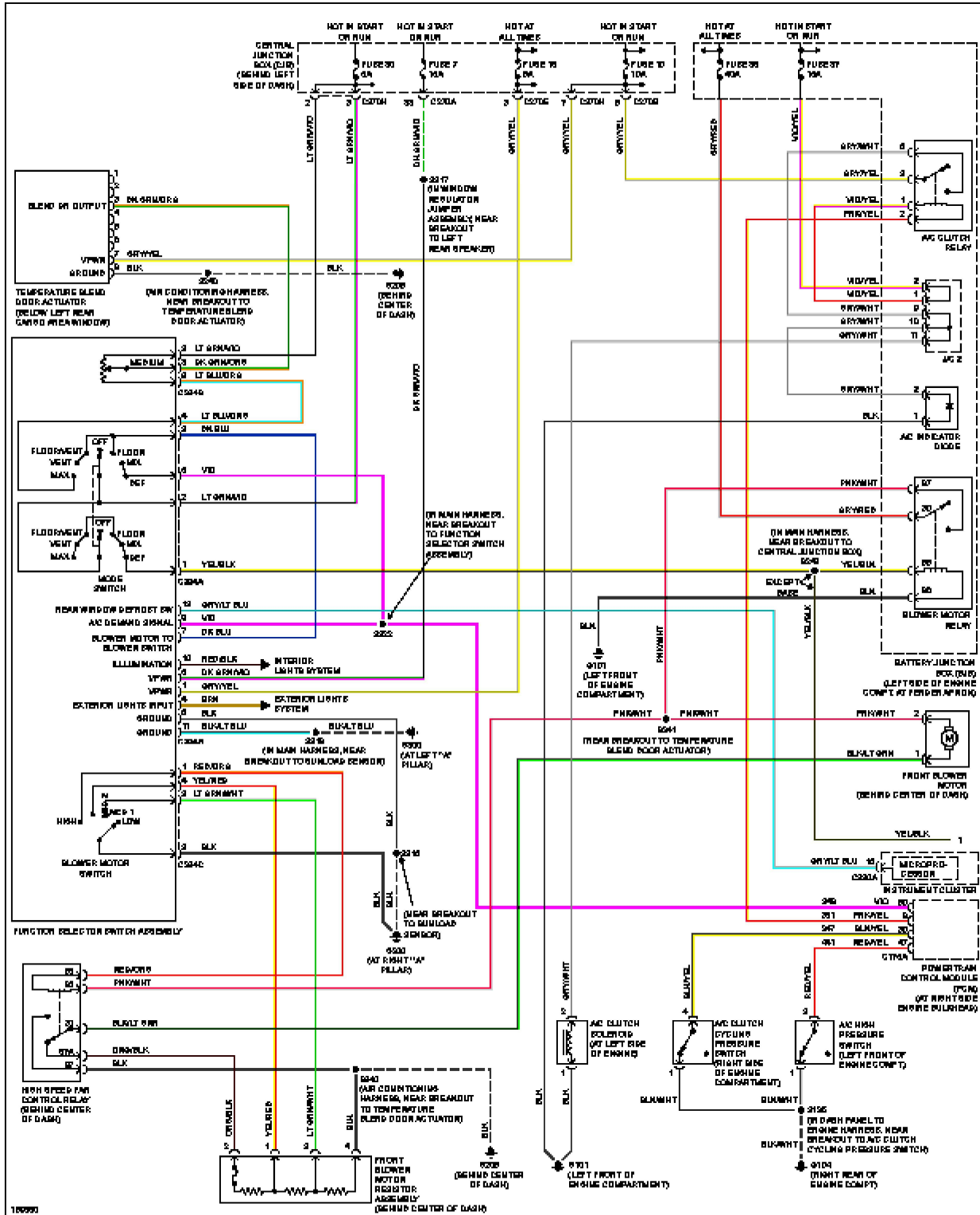

Fig. 3: Manual A/C Circuit, W/ Sliding Roof (1 of 2)

# 2003 Ford Explorer

## SYSTEM WIRING DIAGRAMS 'Ford - Explorer

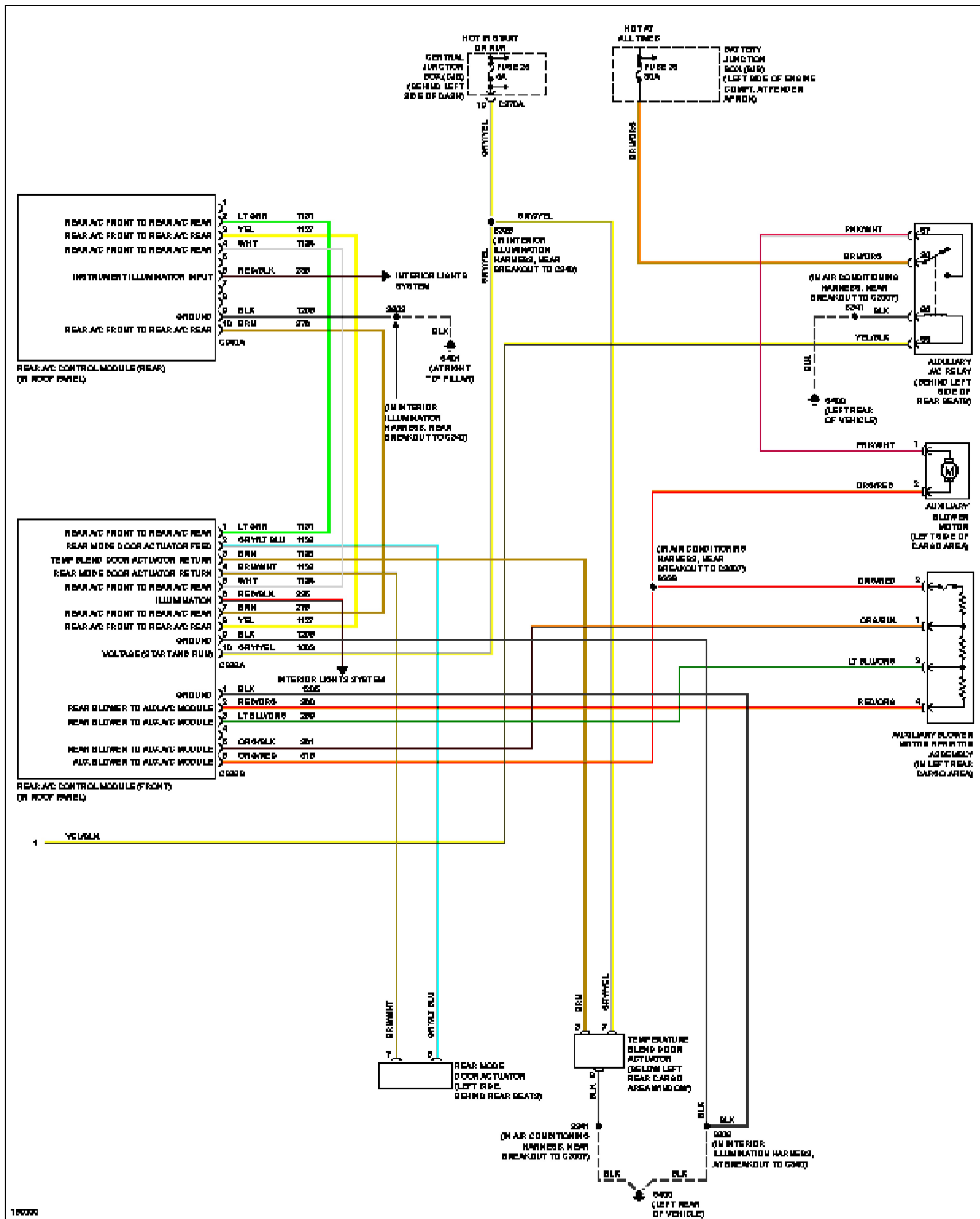

Fig. 4: Manual A/C Circuit, W/ Sliding Roof (2 of 2)

# 2003 Ford Explorer

## SYSTEM WIRING DIAGRAMS 'Ford - Explorer

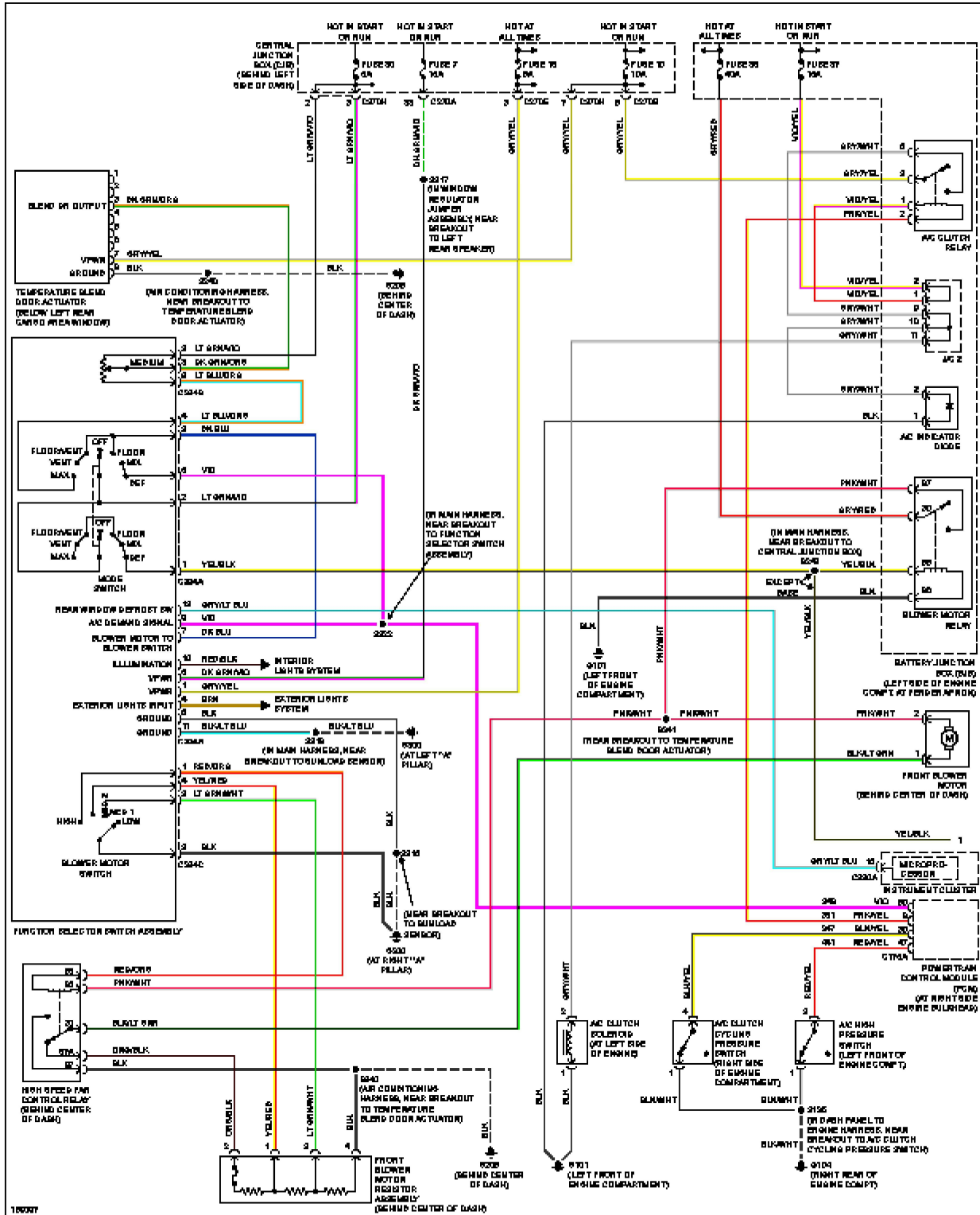

Fig. 5: Manual A/C Circuit, W/O Sliding Roof (1 of 2)

# 2003 Ford Explorer

## SYSTEM WIRING DIAGRAMS 'Ford - Explorer

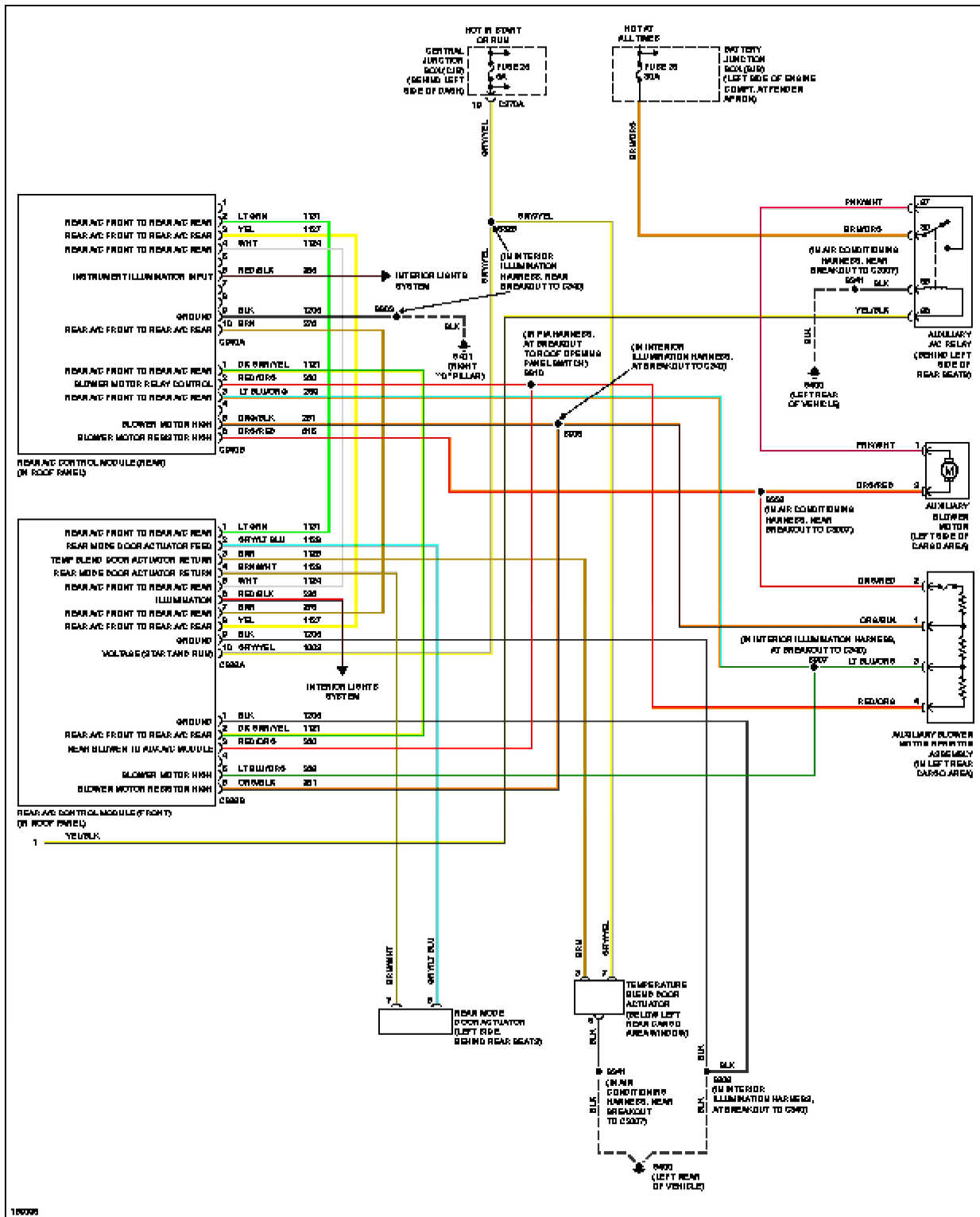
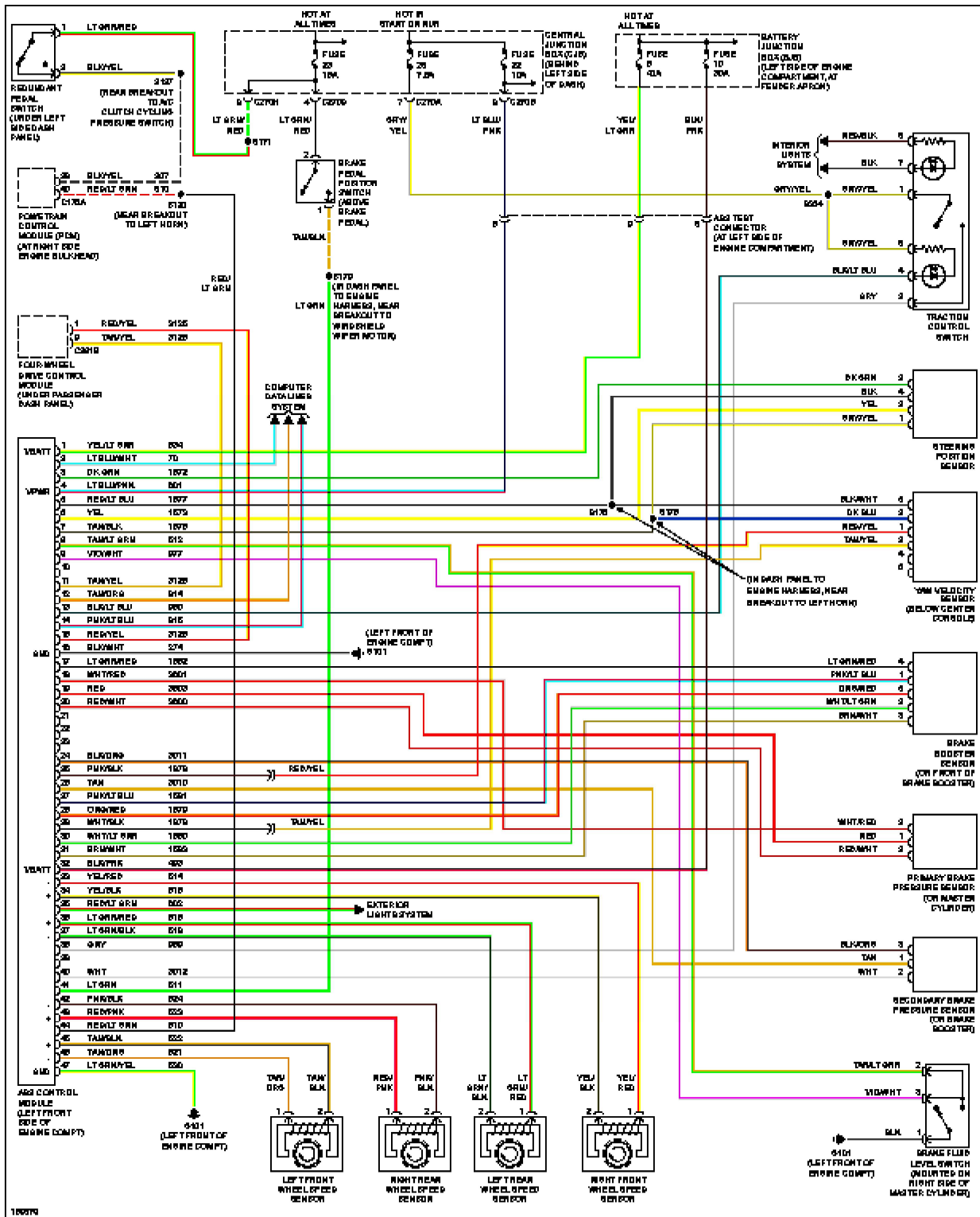

Fig. 6: Manual A/C Circuit, W/O Sliding Roof (2 of 2)

## **ANTI-LOCK BRAKES**

# 2003 Ford Explorer

## SYSTEM WIRING DIAGRAMS 'Ford - Explorer



**Fig. 7: Anti-lock Brakes Circuit, W/ IVD**

# 2003 Ford Explorer

## SYSTEM WIRING DIAGRAMS 'Ford - Explorer

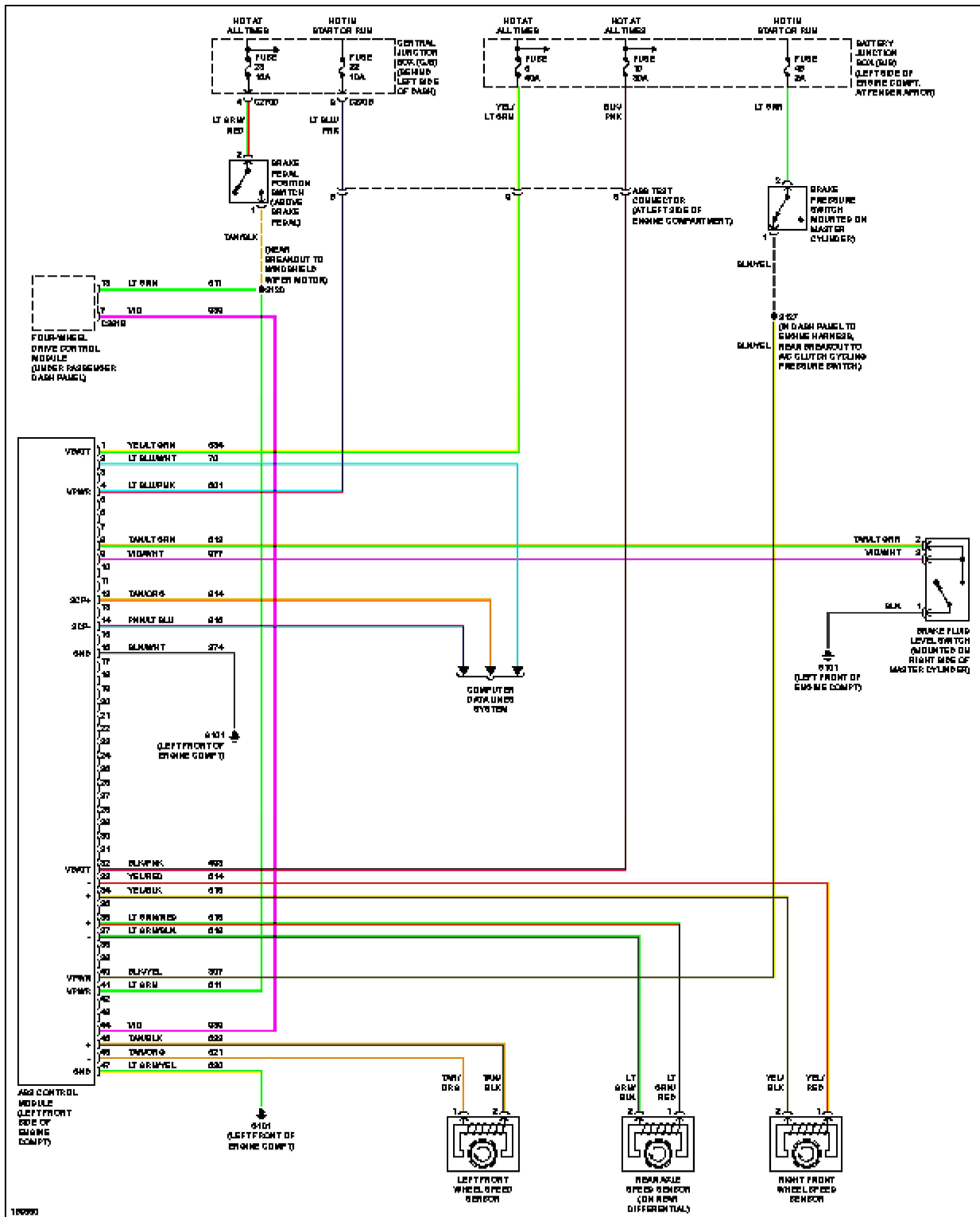

**Fig. 8: Anti-lock Brakes Circuit, W/O IVD**



**2003 Ford Explorer**

SYSTEM WIRING DIAGRAMS' 'Ford - Explorer

**ANTI-THEFT**

# 2003 Ford Explorer

## SYSTEM WIRING DIAGRAMS 'Ford - Explorer

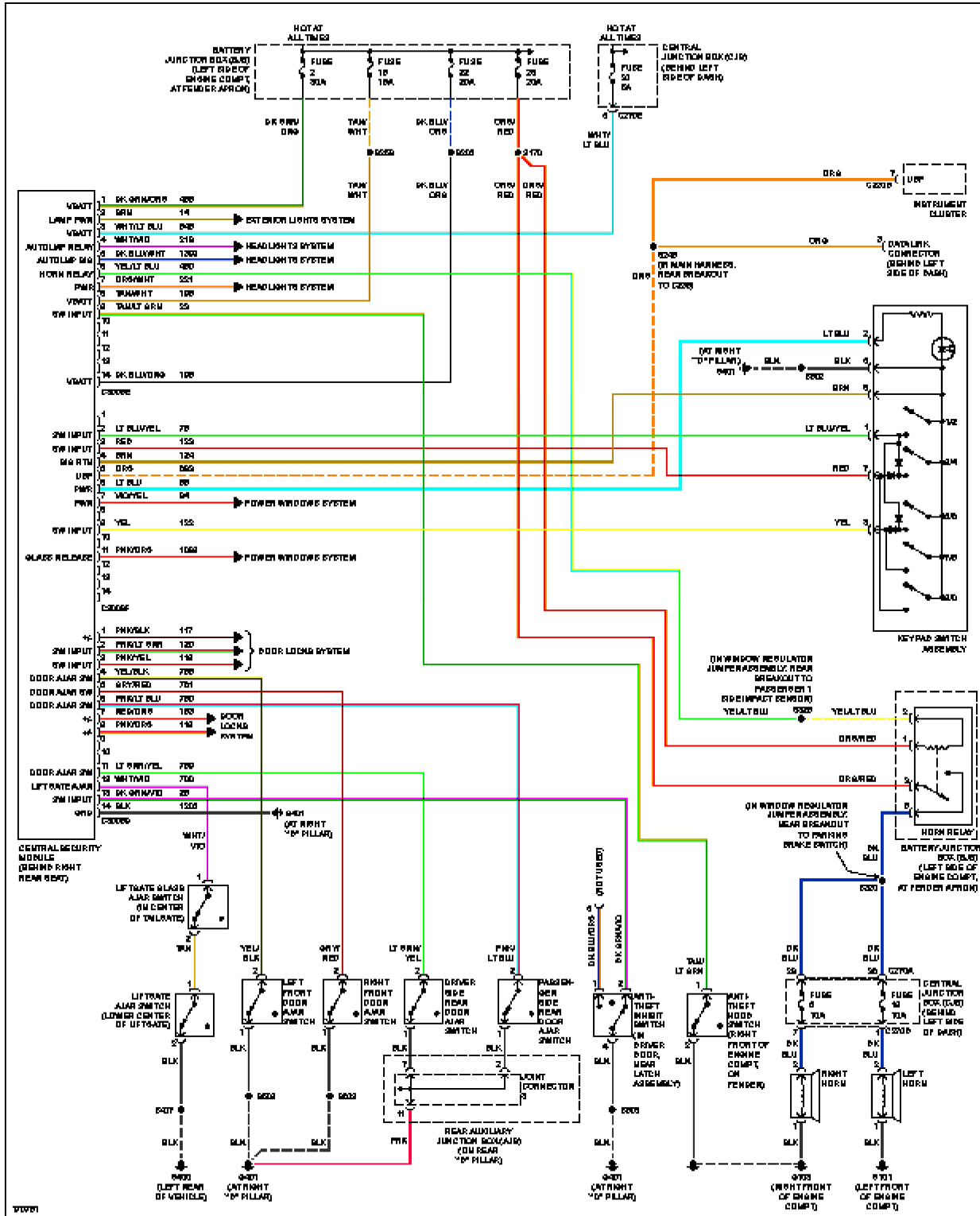

**Fig. 9: Forced Entry Circuit**

# 2003 Ford Explorer

## SYSTEM WIRING DIAGRAMS 'Ford - Explorer

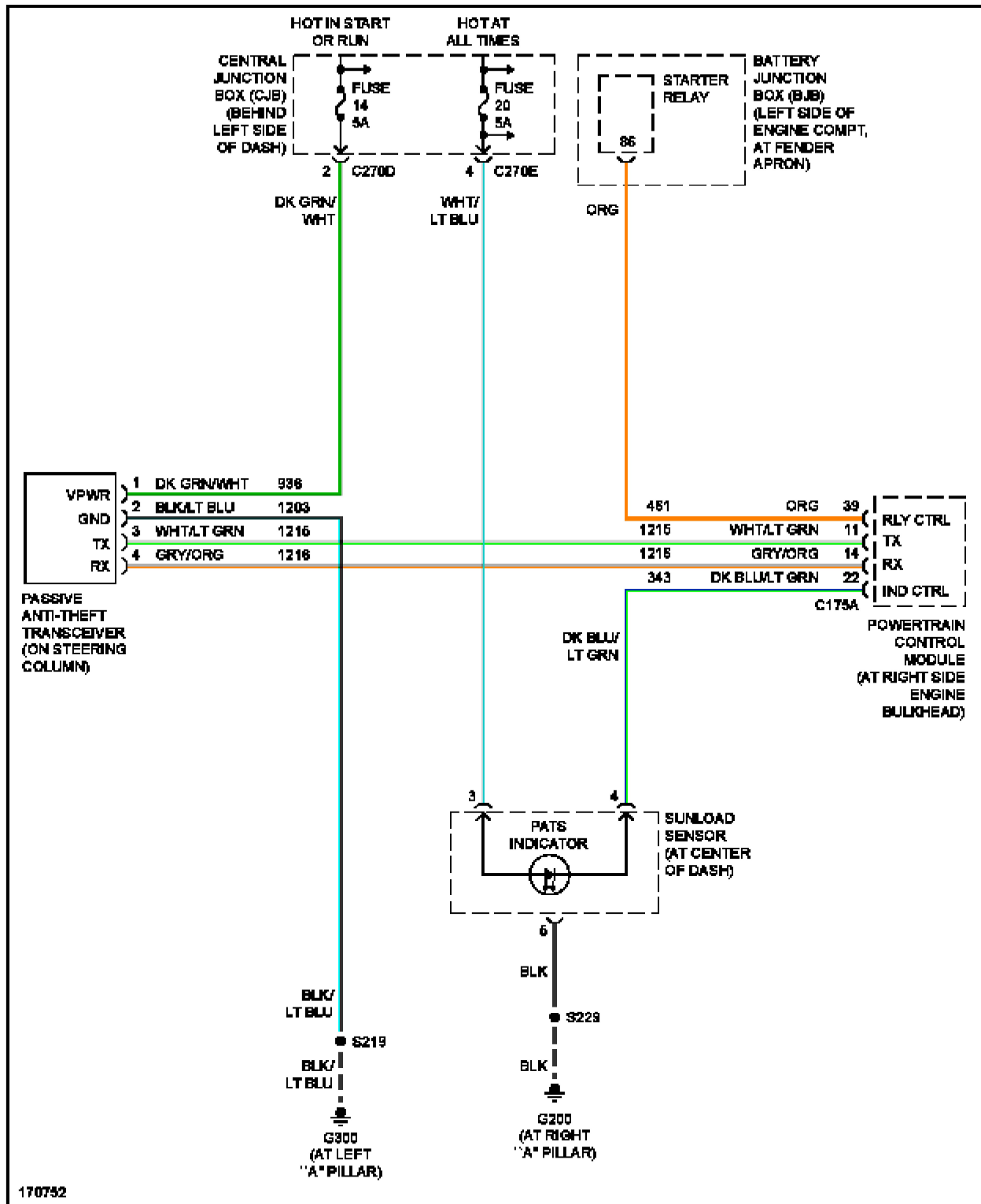
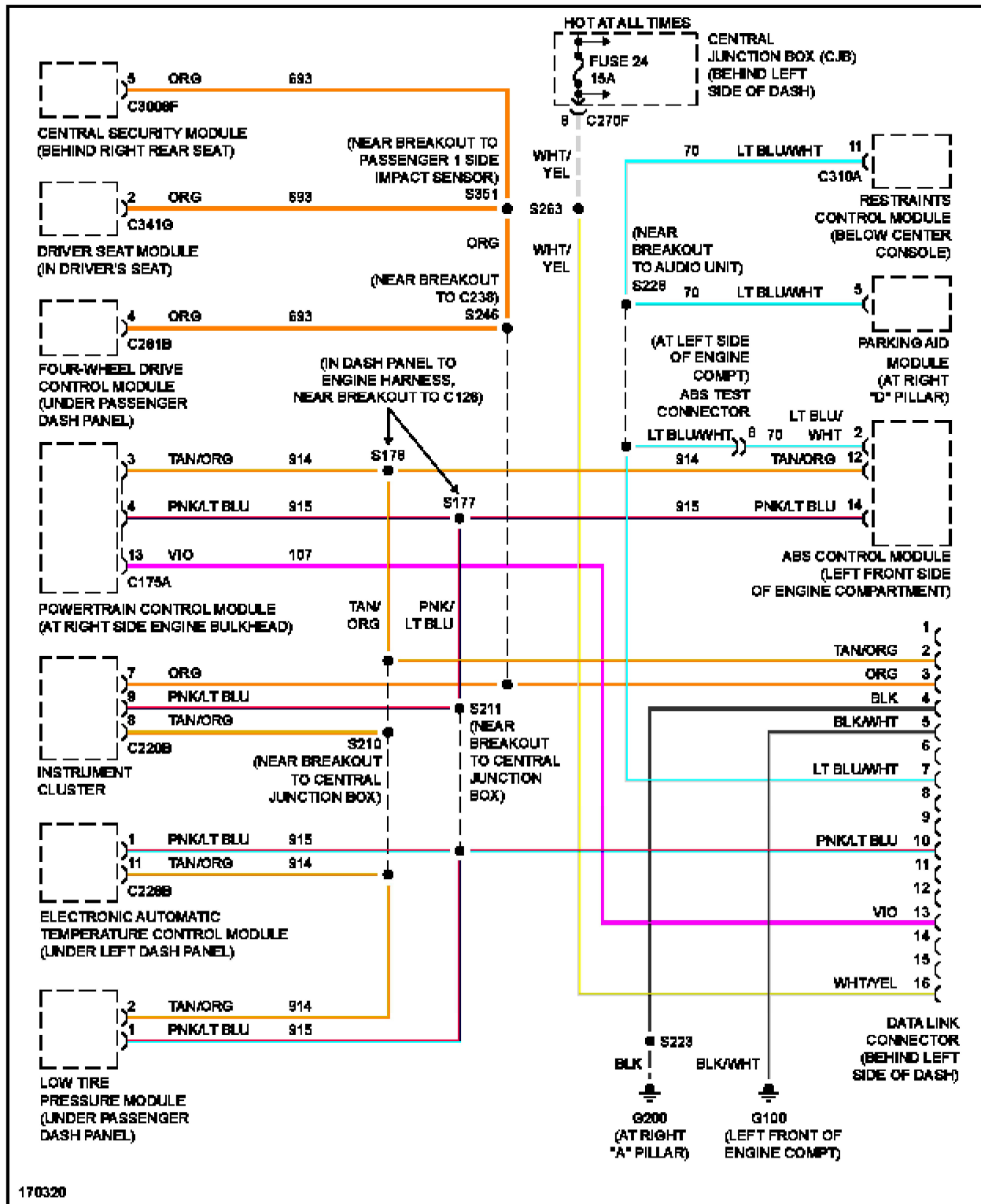

**Fig. 10: Passive Anti-theft Circuit**

## COMPUTER DATA LINES

# 2003 Ford Explorer

## SYSTEM WIRING DIAGRAMS 'Ford - Explorer



170320

**Fig. 11: Computer Data Lines Circuit**

## **CRUISE CONTROL**

# 2003 Ford Explorer

## SYSTEM WIRING DIAGRAMS 'Ford - Explorer

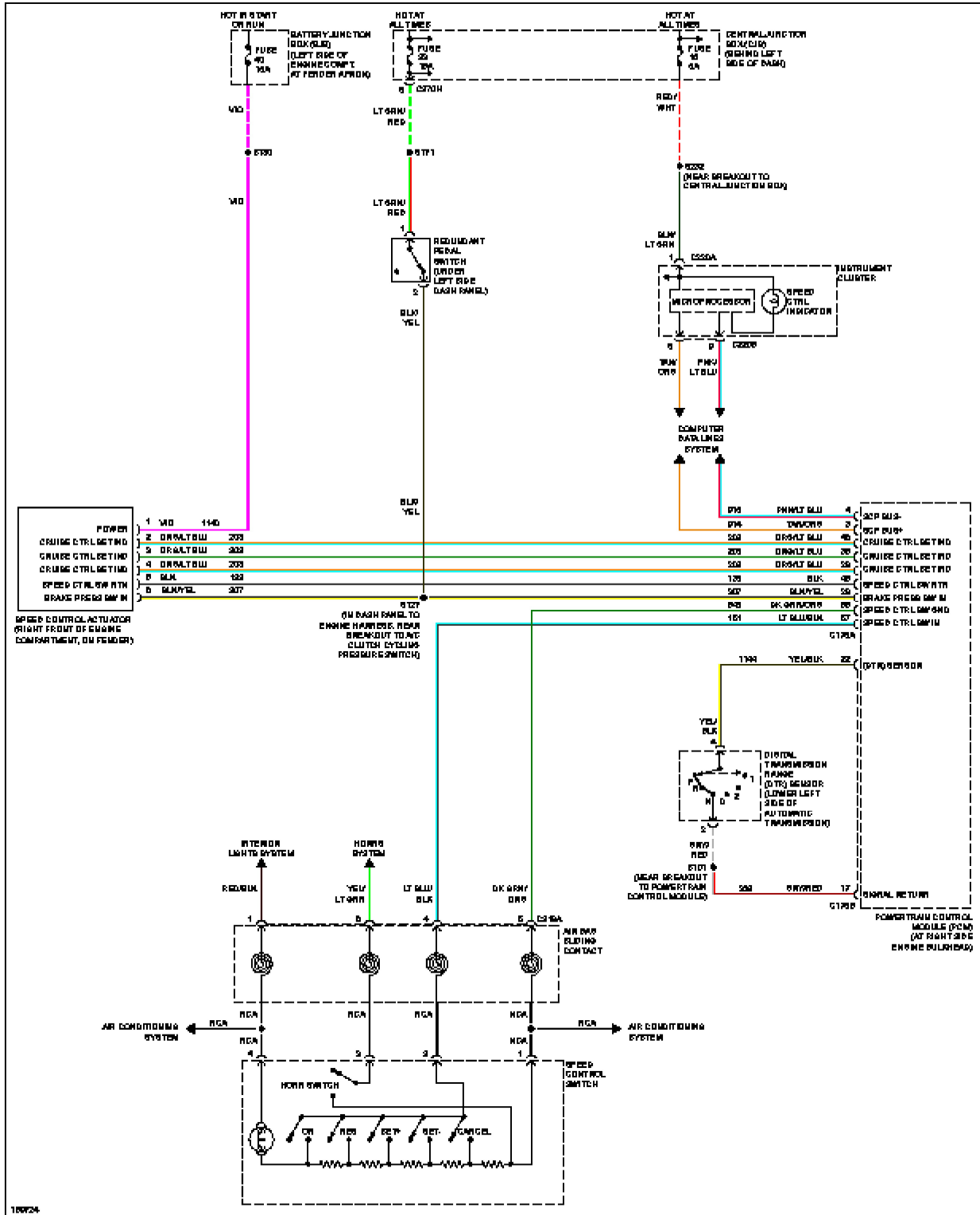

**Fig. 12: Cruise Control Circuit, W/ IVD**

# 2003 Ford Explorer

## SYSTEM WIRING DIAGRAMS 'Ford - Explorer

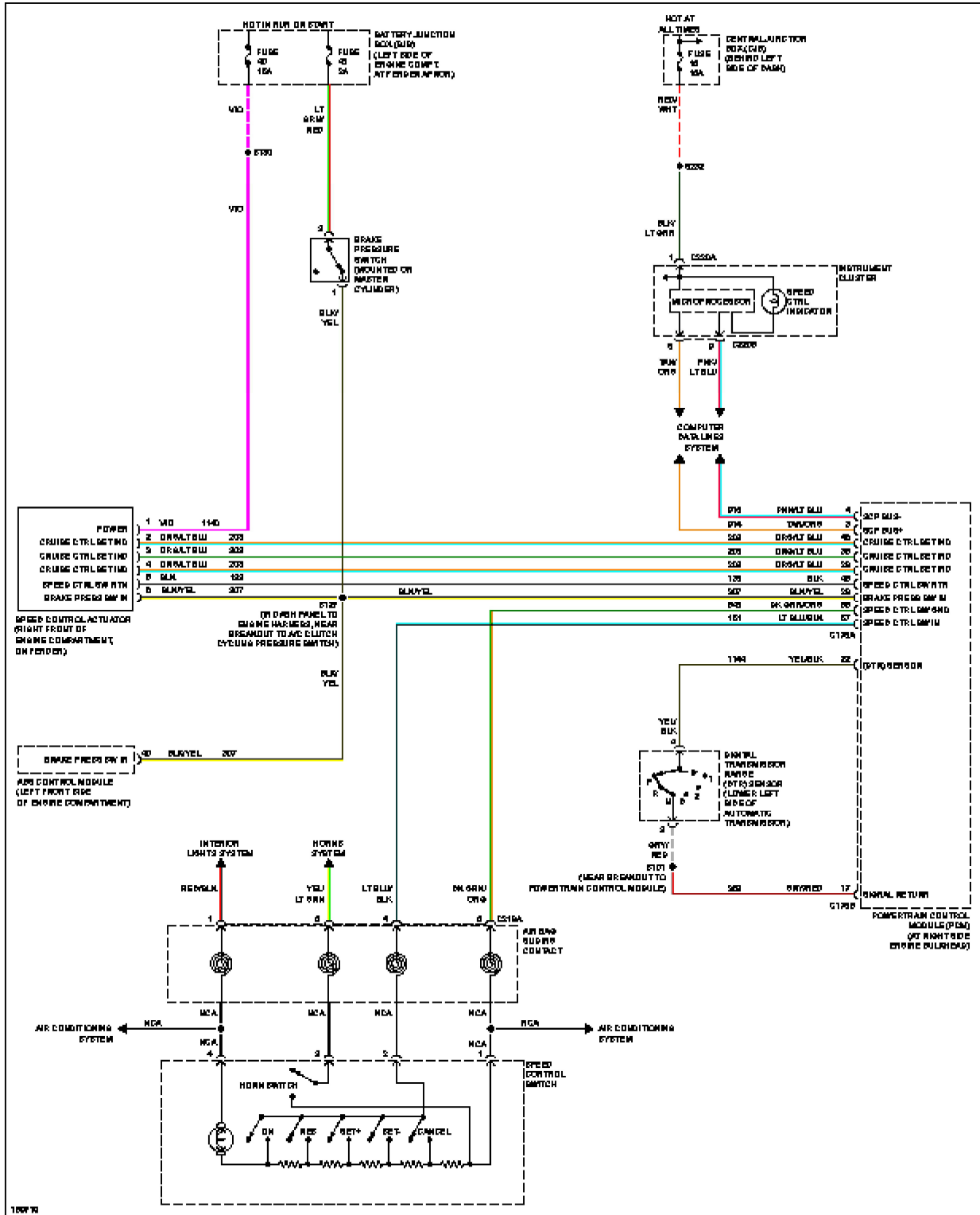

**Fig. 13: Cruise Control Circuit, W/O IVD**



## **DEFOGGERS**

# 2003 Ford Explorer

## SYSTEM WIRING DIAGRAMS 'Ford - Explorer

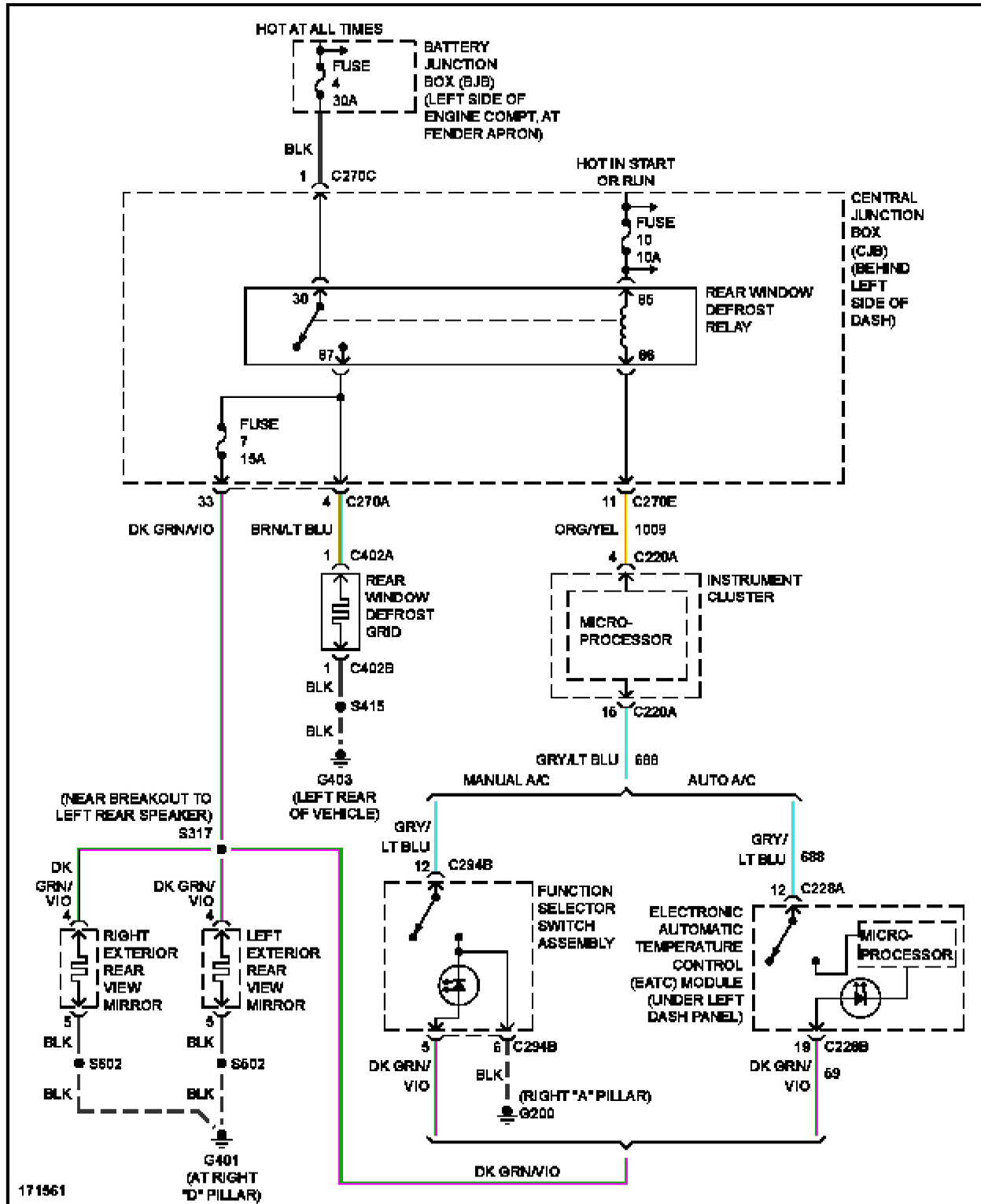

**Fig. 14: Defoggers Circuit**

## **ENGINE PERFORMANCE**

**4.0L**

# 2003 Ford Explorer

## SYSTEM WIRING DIAGRAMS 'Ford - Explorer

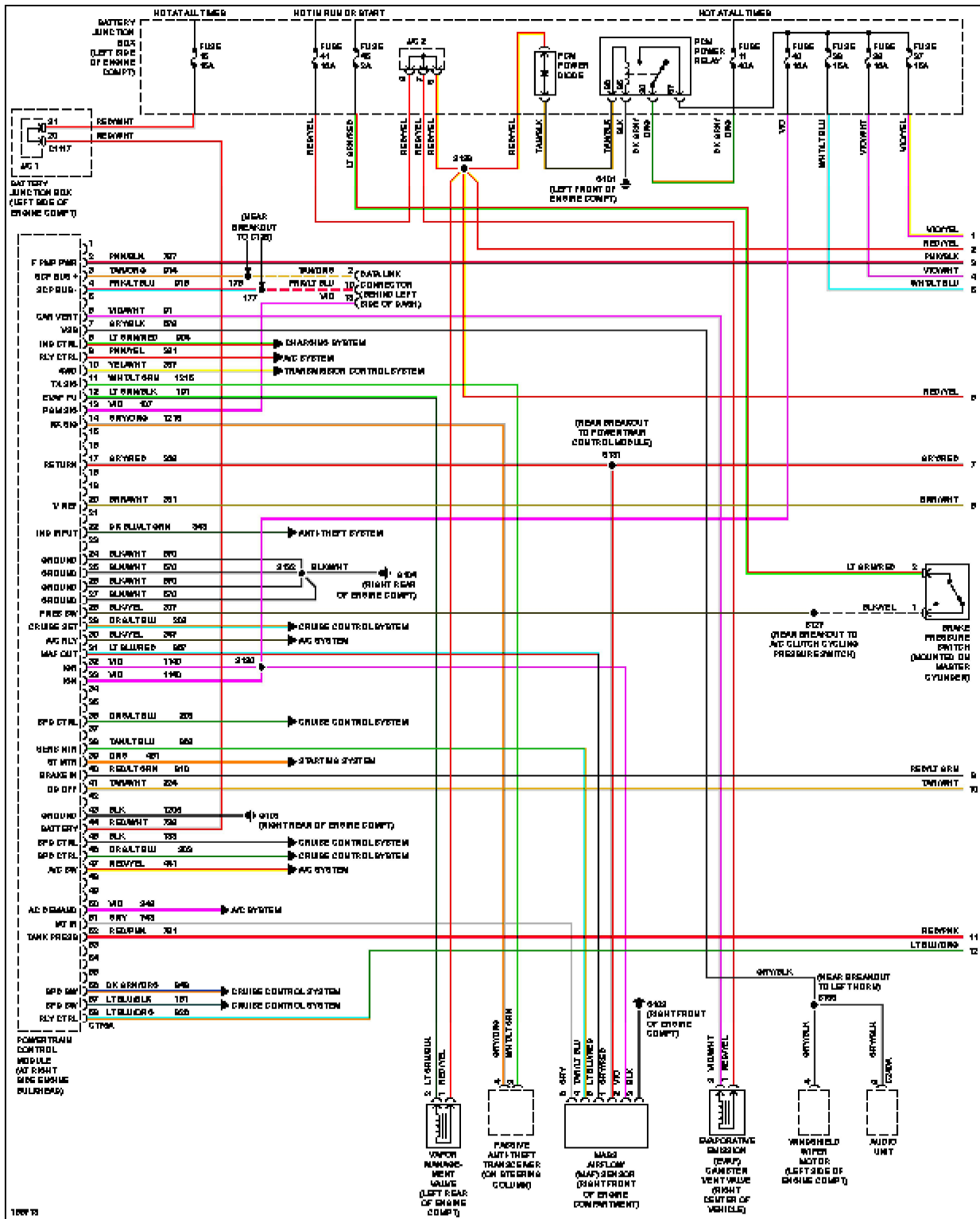

Fig. 15: 4.0L, Engine Performance Circuit (1 of 4)

# 2003 Ford Explorer

## SYSTEM WIRING DIAGRAMS 'Ford - Explorer

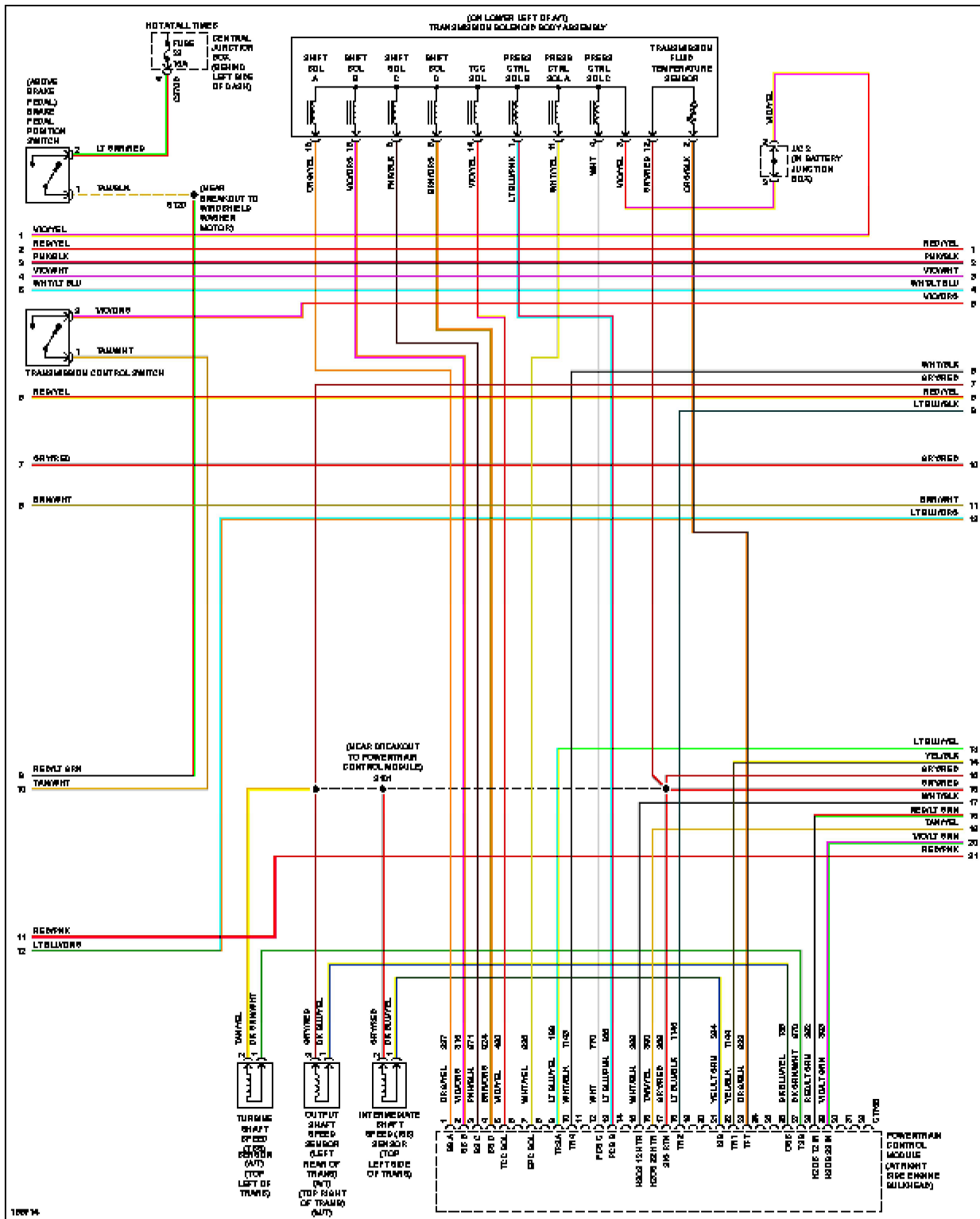

Fig. 16: 4.0L, Engine Performance Circuit (2 of 4)

# 2003 Ford Explorer

## SYSTEM WIRING DIAGRAMS 'Ford - Explorer

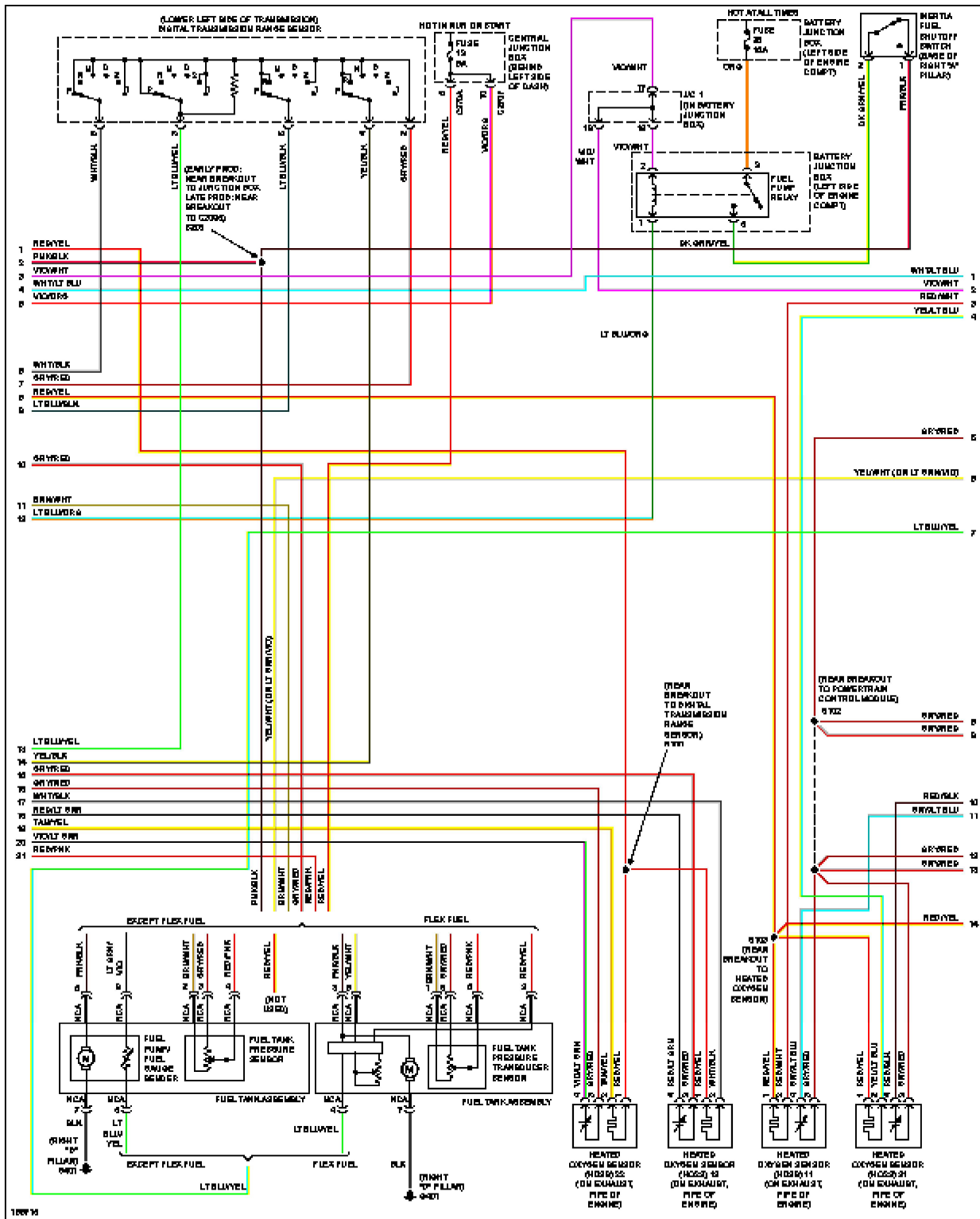

Fig. 17: 4.0L, Engine Performance Circuit (3 of 4)

# 2003 Ford Explorer

## SYSTEM WIRING DIAGRAMS 'Ford - Explorer

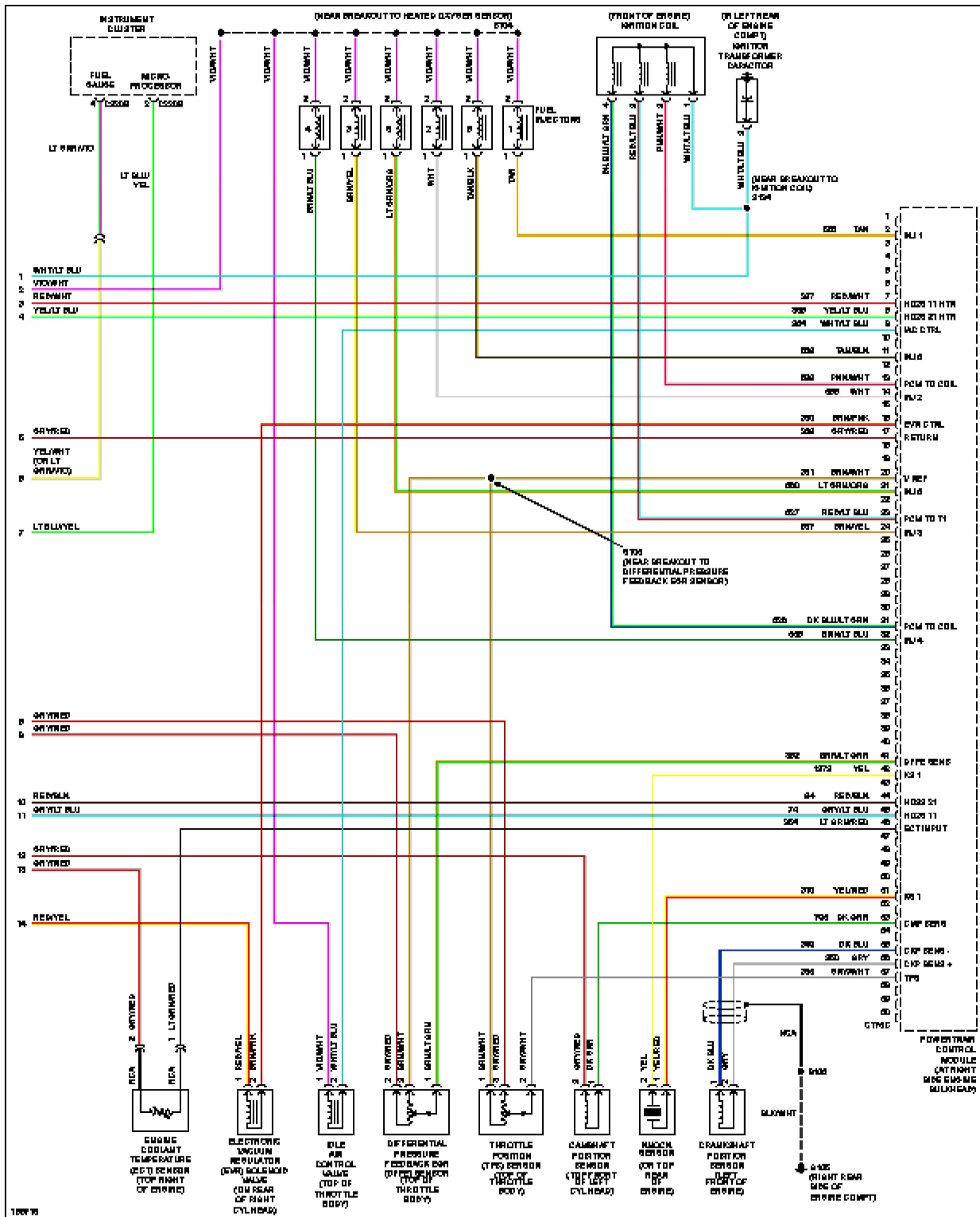

Fig. 18: 4.0L, Engine Performance Circuit (4 of 4)

## 2003 Ford Explorer

### SYSTEM WIRING DIAGRAMS' 'Ford - Explorer

**4.6L**



# 2003 Ford Explorer

## SYSTEM WIRING DIAGRAMS 'Ford - Explorer

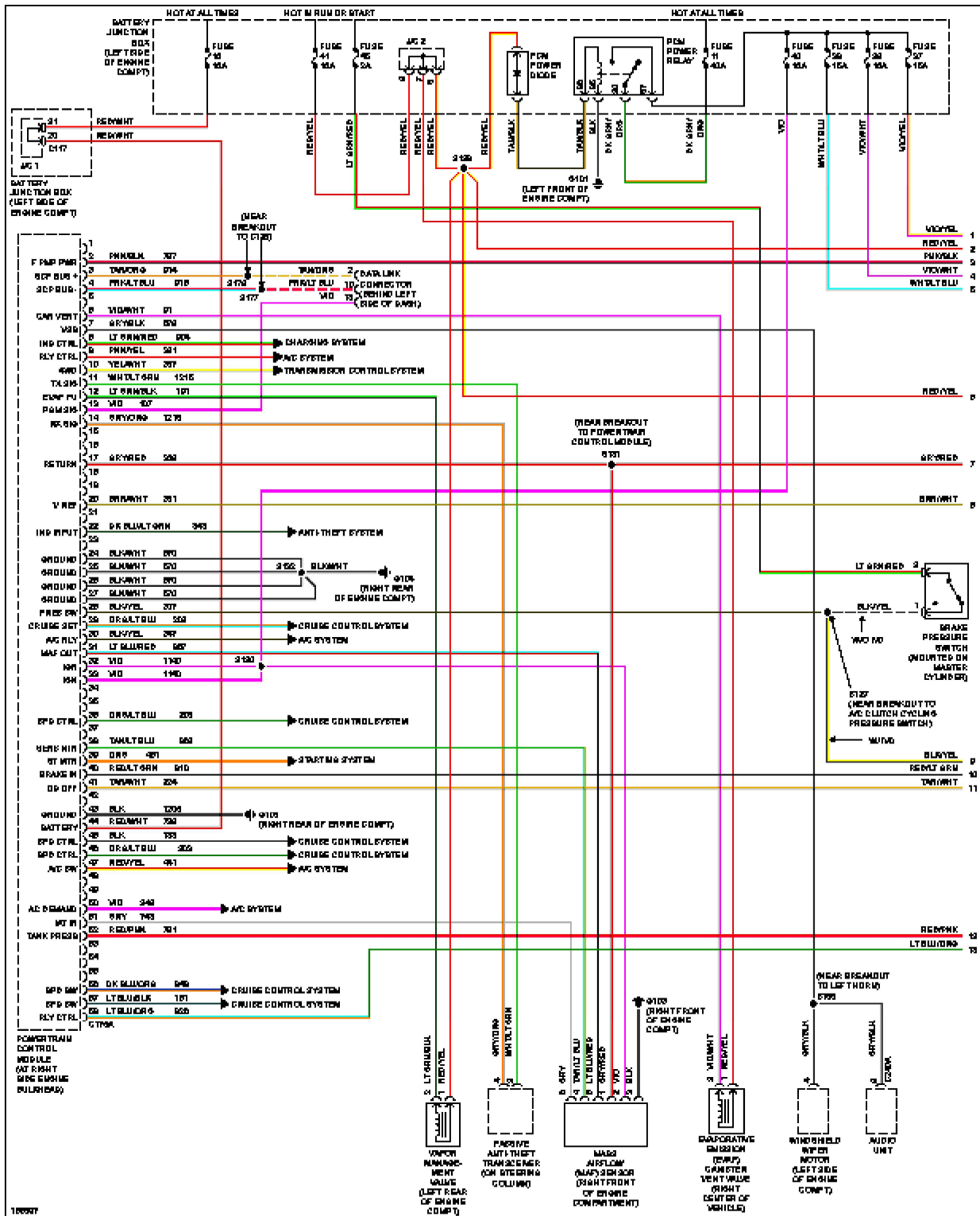

**Fig. 19: 4.6L, Engine Performance Circuit (1 of 4)**

# 2003 Ford Explorer

## SYSTEM WIRING DIAGRAMS 'Ford - Explorer

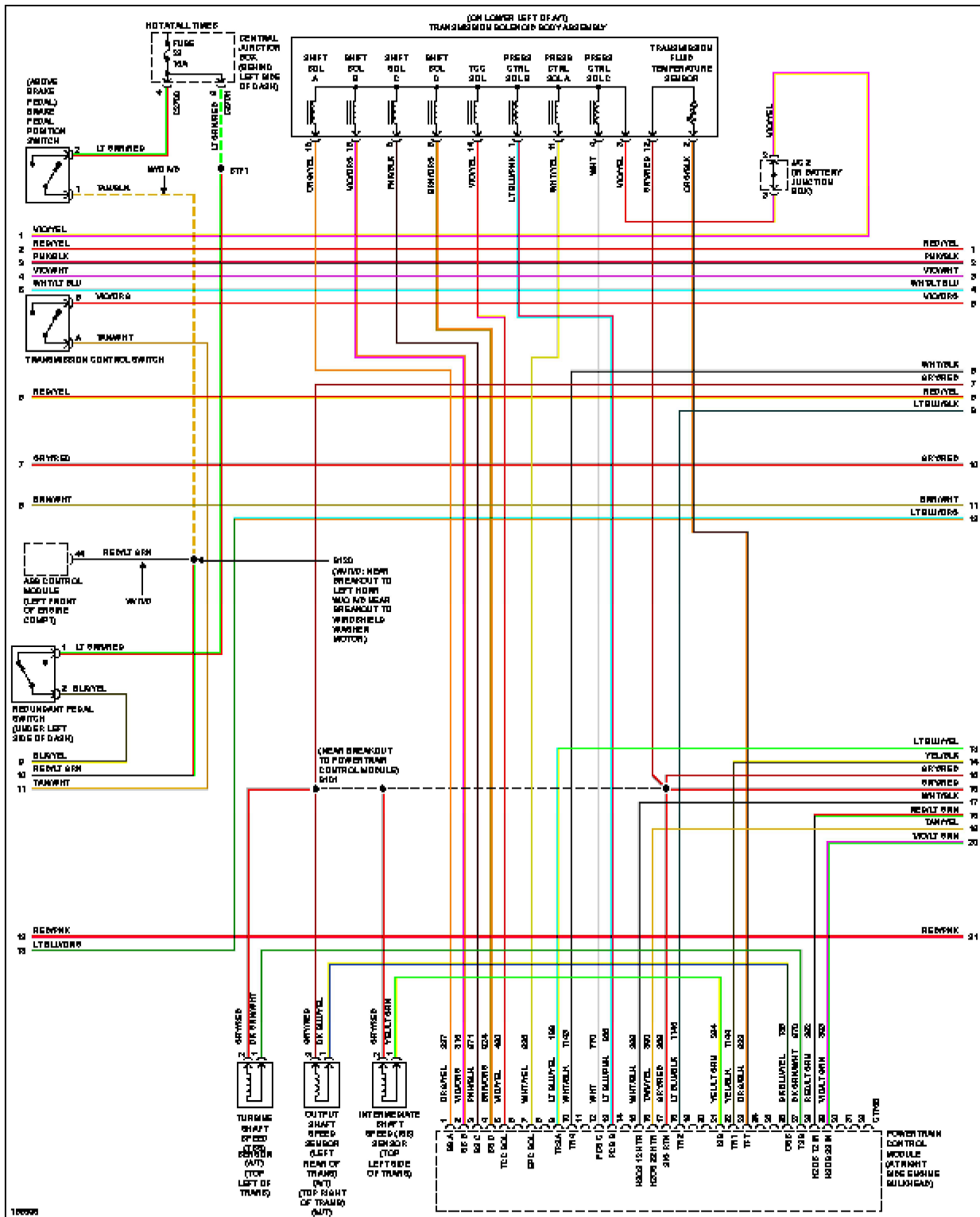

Fig. 20: 4.6L, Engine Performance Circuit (2 of 4)

# 2003 Ford Explorer

## SYSTEM WIRING DIAGRAMS 'Ford - Explorer

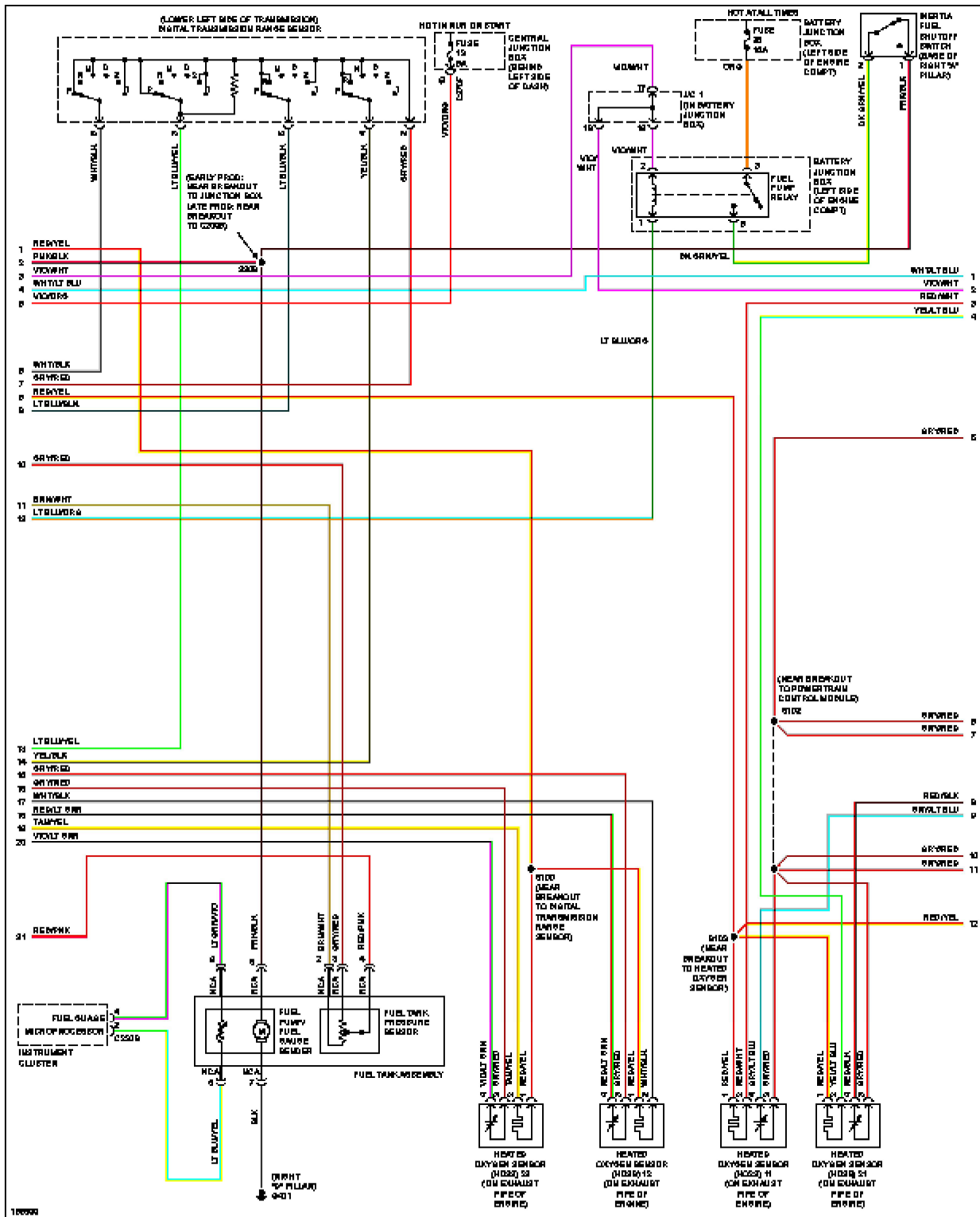

Fig. 21: 4.6L, Engine Performance Circuit (3 of 4)

# 2003 Ford Explorer

## SYSTEM WIRING DIAGRAMS 'Ford - Explorer

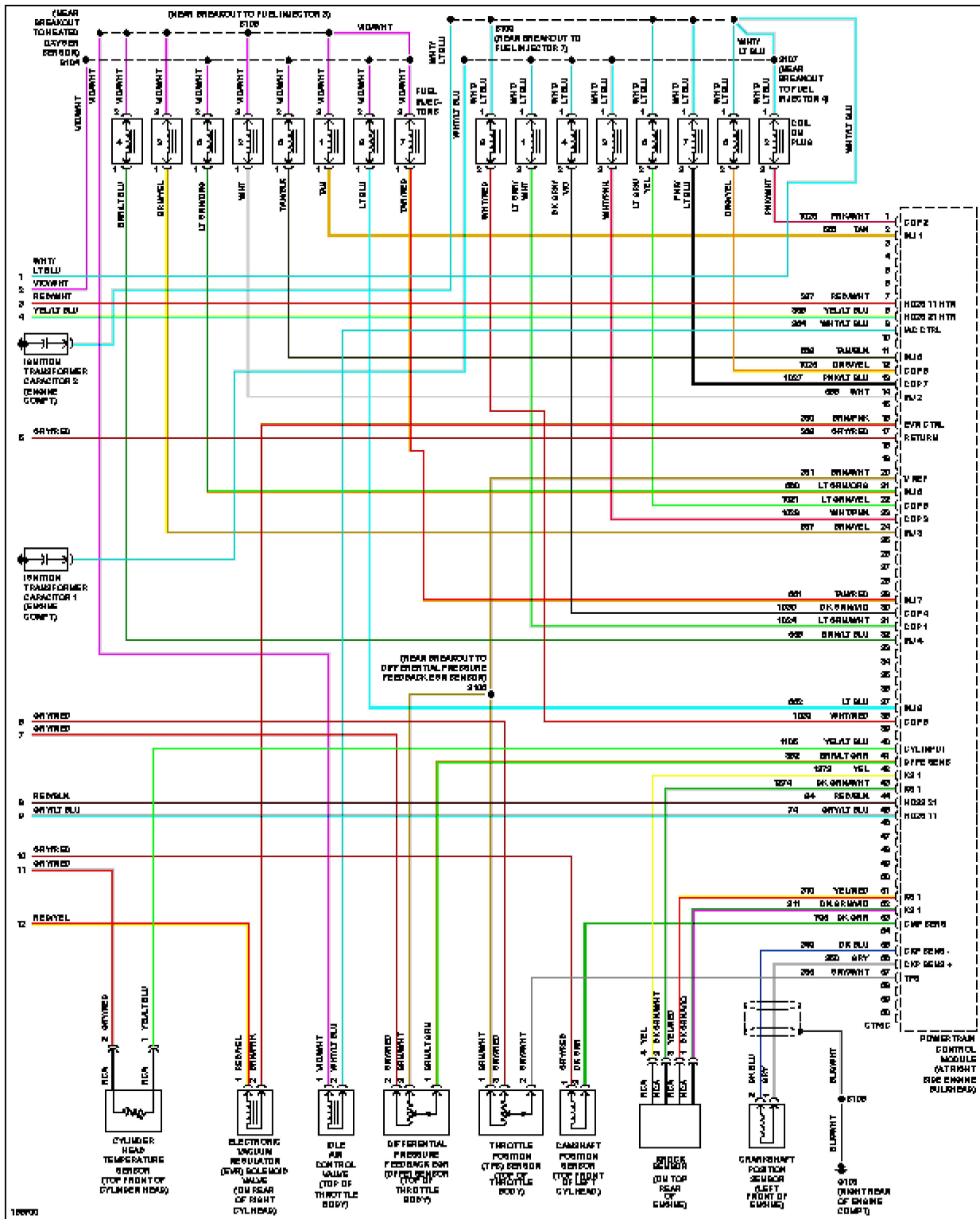
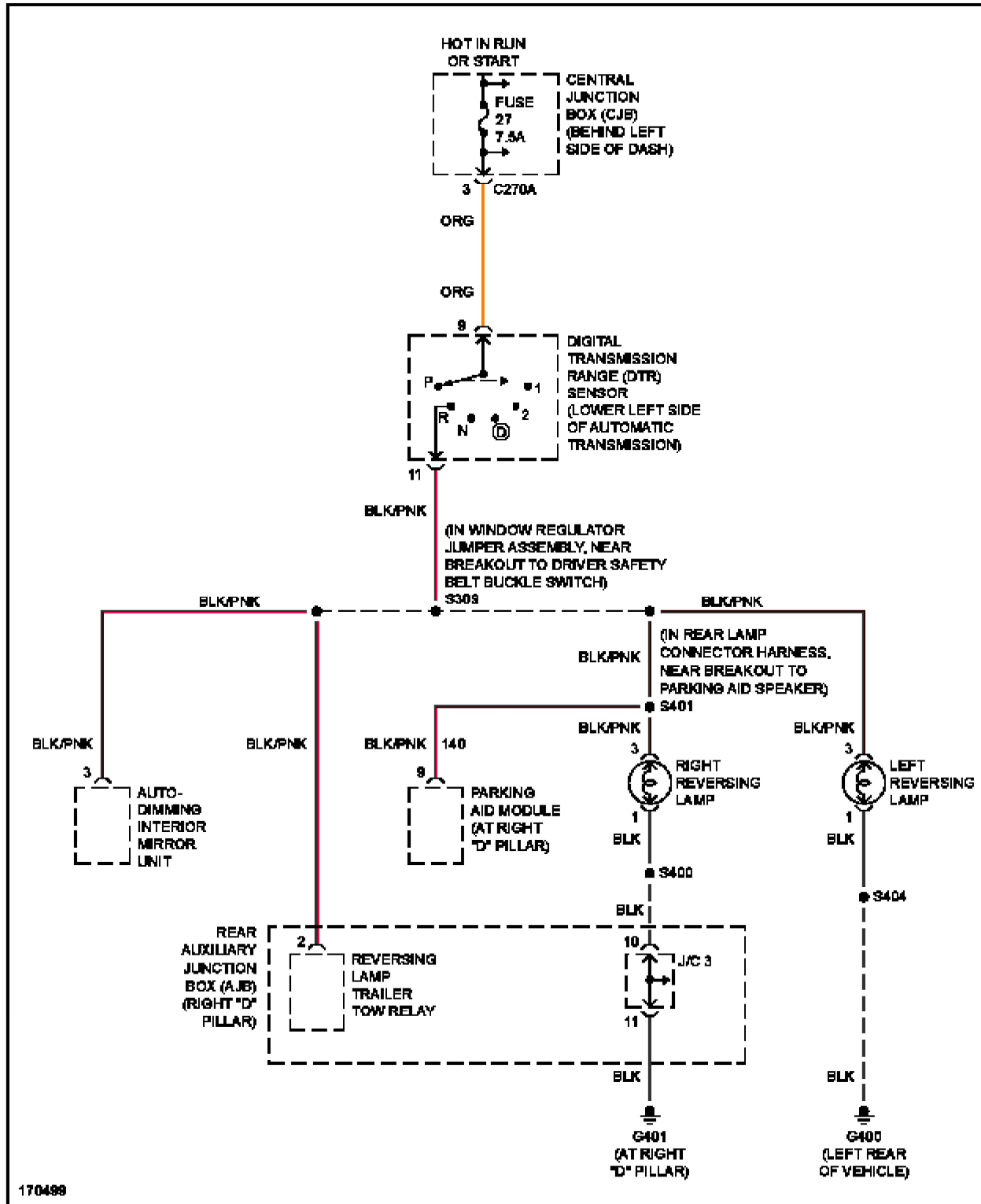

Fig. 22: 4.6L, Engine Performance Circuit (4 of 4)

## **EXTERIOR LIGHTS**

# 2003 Ford Explorer

## SYSTEM WIRING DIAGRAMS 'Ford - Explorer



**Fig. 23: Back-up Lamps Circuit**

# 2003 Ford Explorer

## SYSTEM WIRING DIAGRAMS 'Ford - Explorer

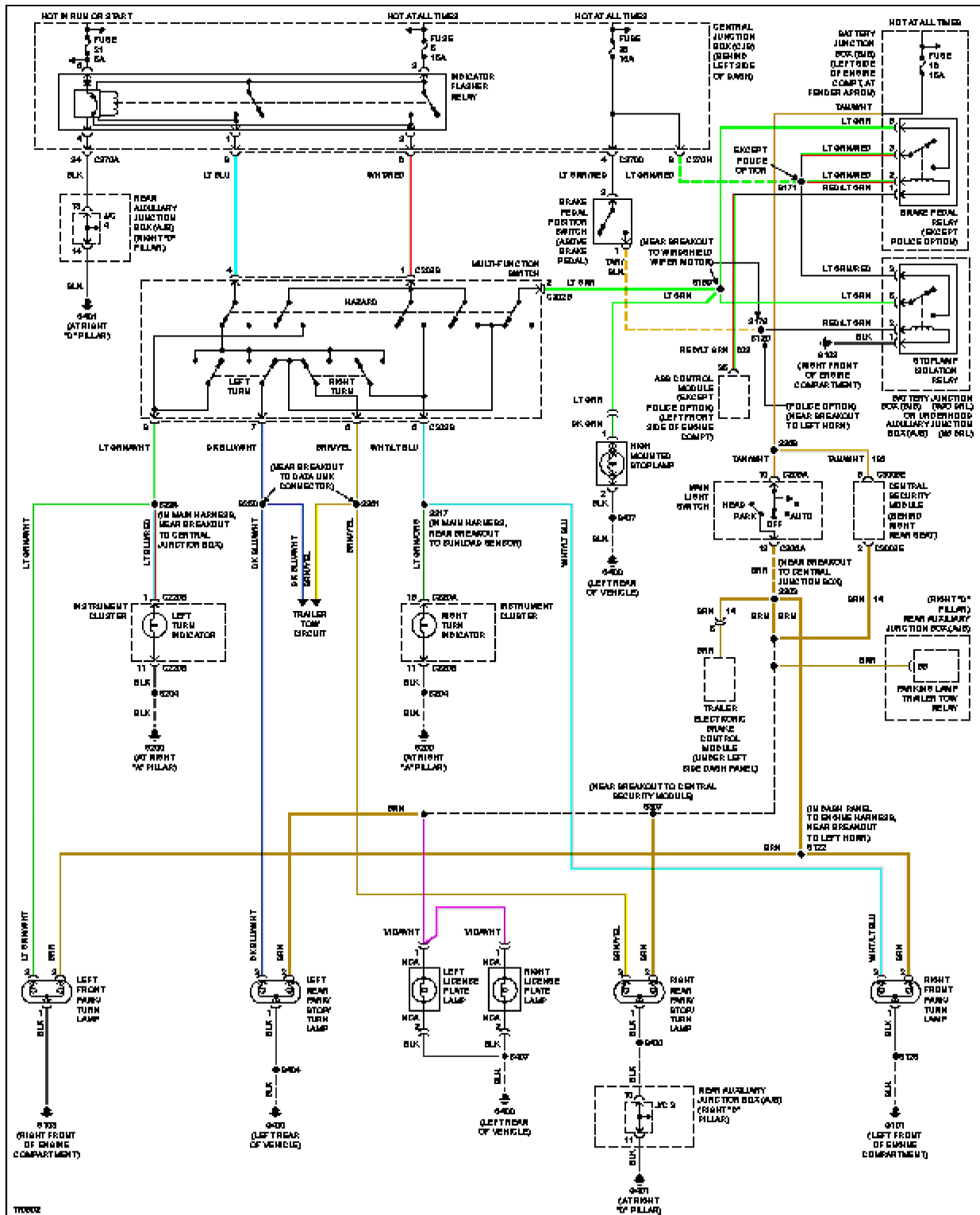

**Fig. 24: Exterior Lamps Circuit, W/ IVD**

# 2003 Ford Explorer

## SYSTEM WIRING DIAGRAMS 'Ford - Explorer

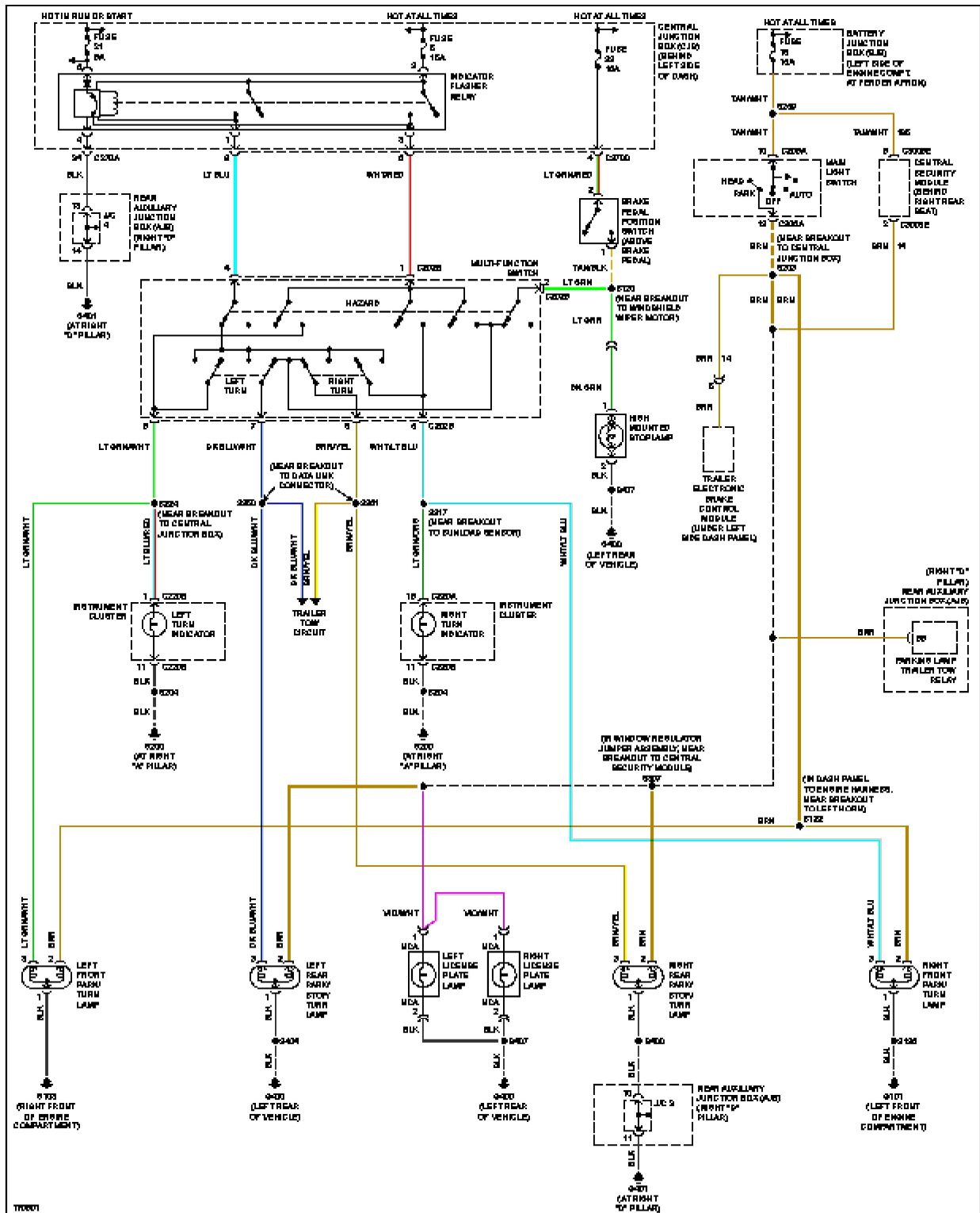
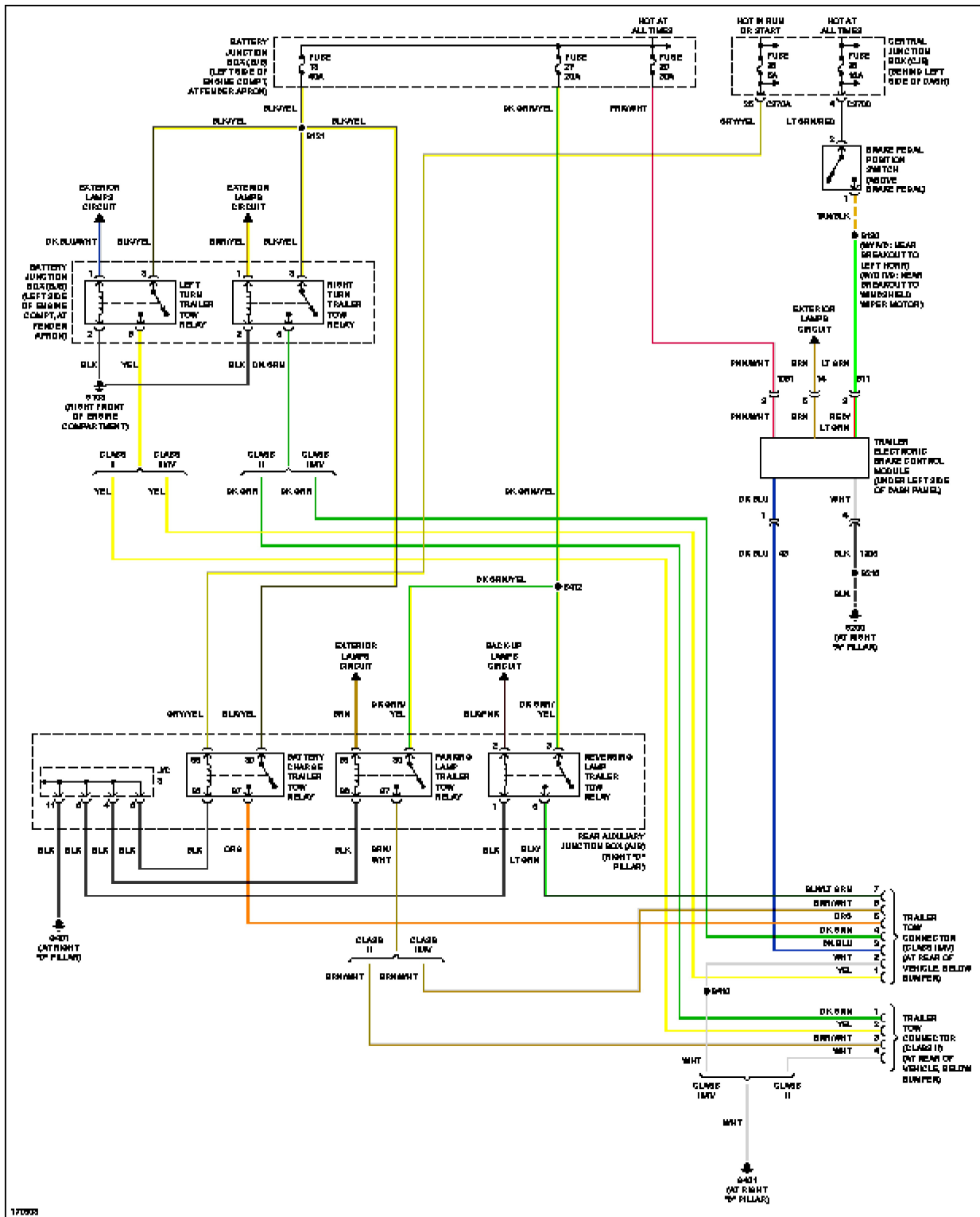

**Fig. 25: Exterior Lamps Circuit, W/O IVD**



# 2003 Ford Explorer

## SYSTEM WIRING DIAGRAMS 'Ford - Explorer



**Fig. 26: Trailer Tow Circuit, Early Production**

# 2003 Ford Explorer

## SYSTEM WIRING DIAGRAMS 'Ford - Explorer

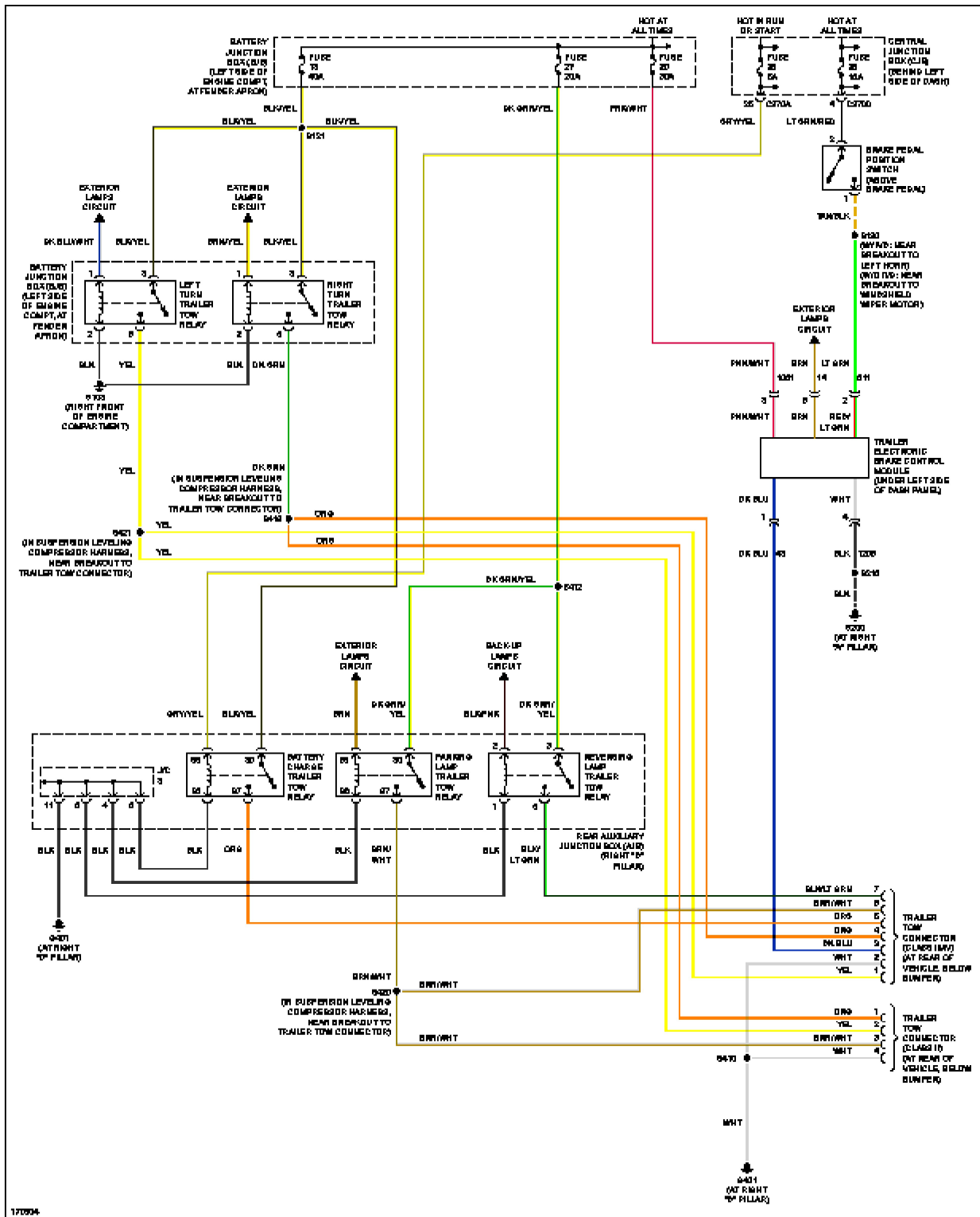

**Fig. 27: Trailer Tow Circuit, Late Production**

## **GROUND DISTRIBUTION**

# 2003 Ford Explorer

## SYSTEM WIRING DIAGRAMS 'Ford - Explorer

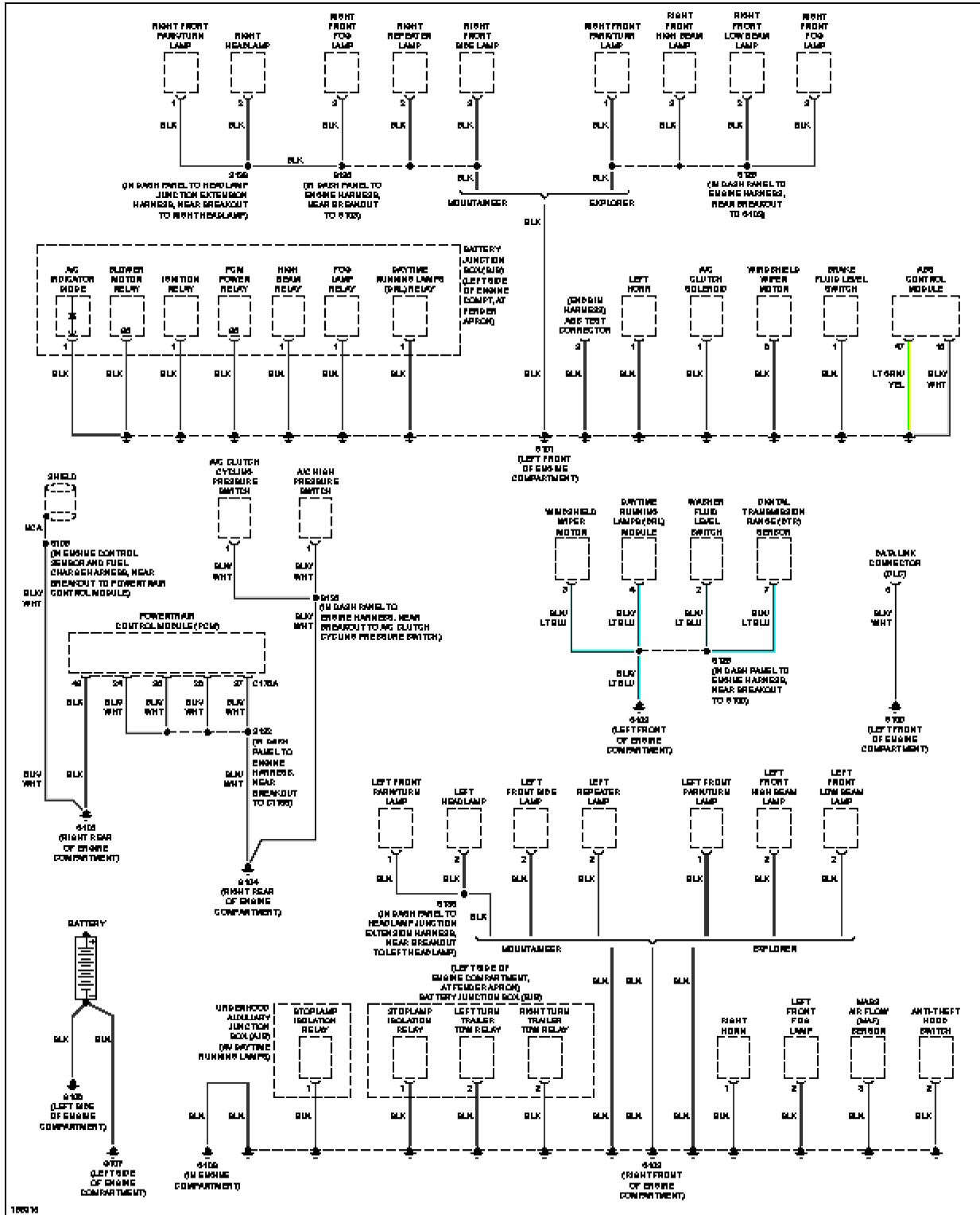

Fig. 28: Ground Distribution Circuit (1 of 4)

# 2003 Ford Explorer

## SYSTEM WIRING DIAGRAMS 'Ford - Explorer

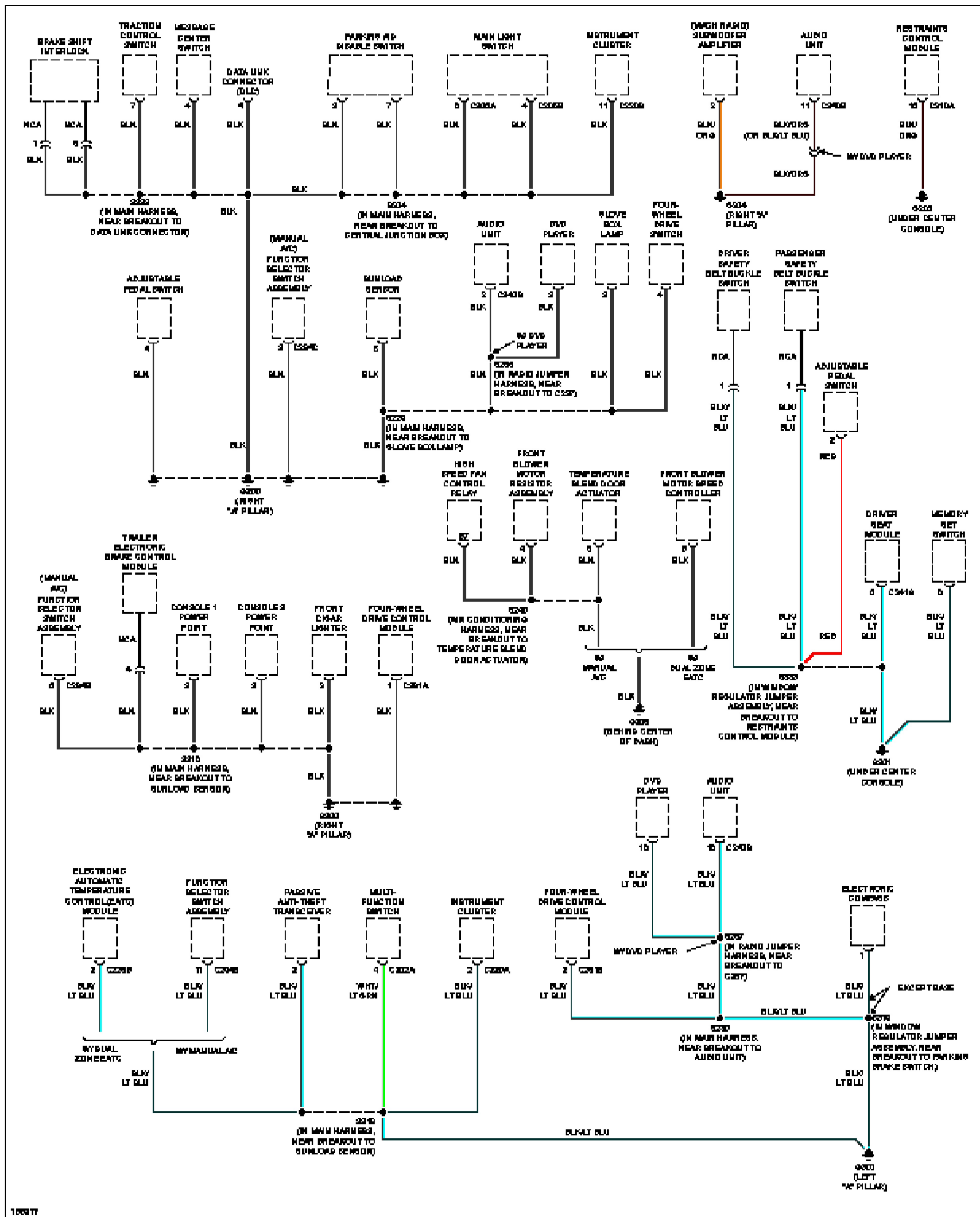
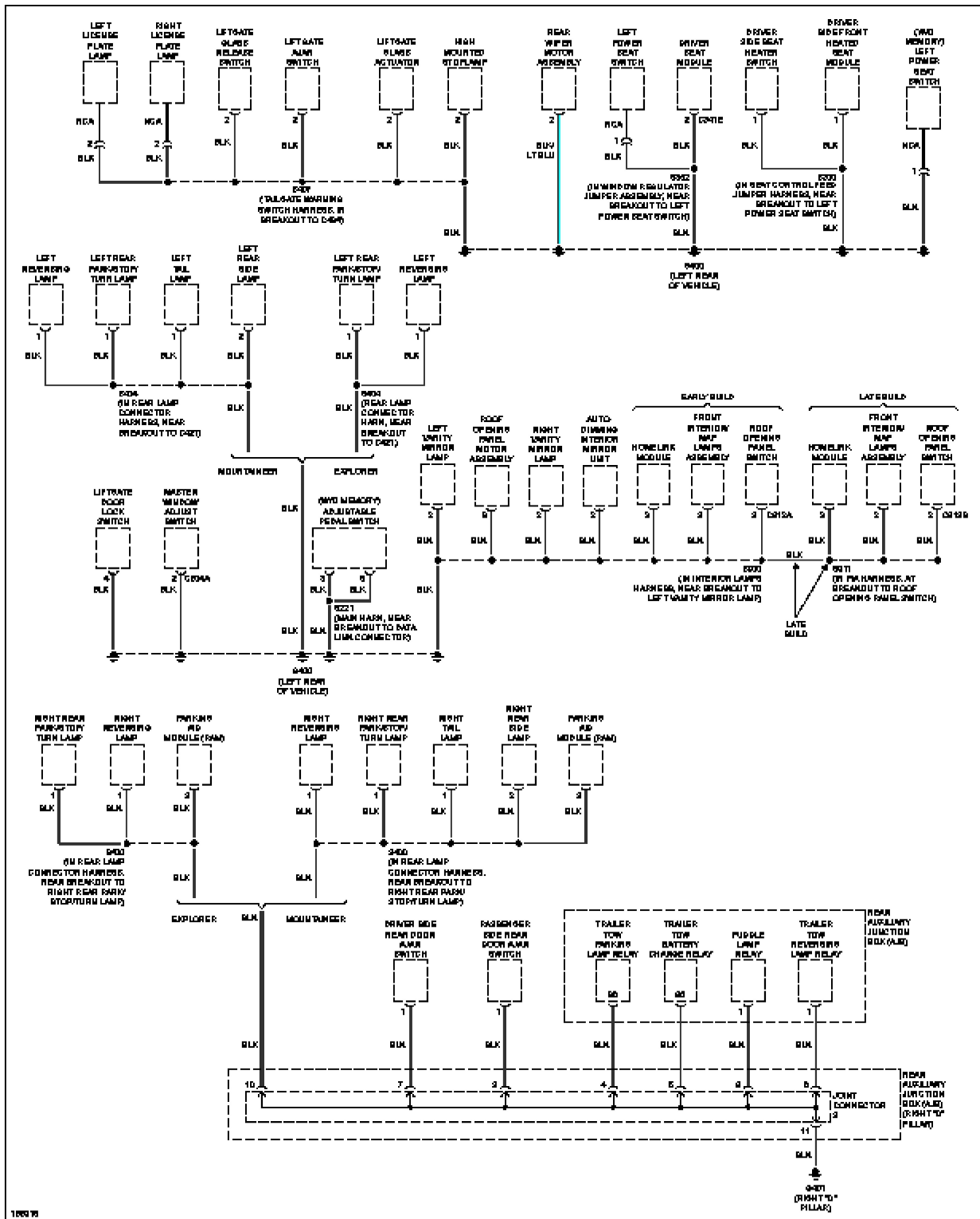

Fig. 29: Ground Distribution Circuit (2 of 4)

# 2003 Ford Explorer

## SYSTEM WIRING DIAGRAMS 'Ford - Explorer



**Fig. 30: Ground Distribution Circuit (3 of 4)**

# 2003 Ford Explorer

## SYSTEM WIRING DIAGRAMS 'Ford - Explorer

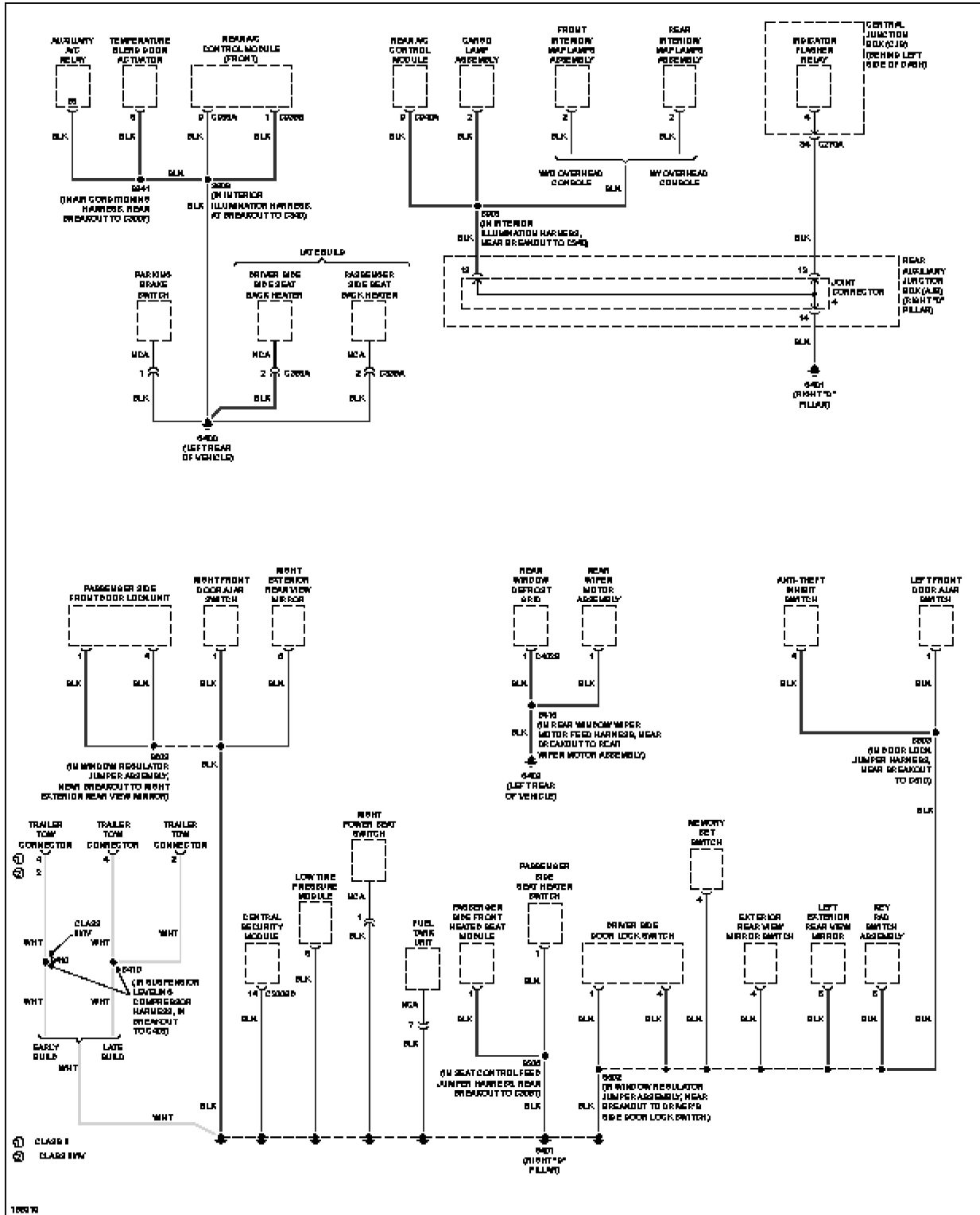

Fig. 31: Ground Distribution Circuit (4 of 4)

## HEADLIGHTS



# 2003 Ford Explorer

## SYSTEM WIRING DIAGRAMS 'Ford - Explorer

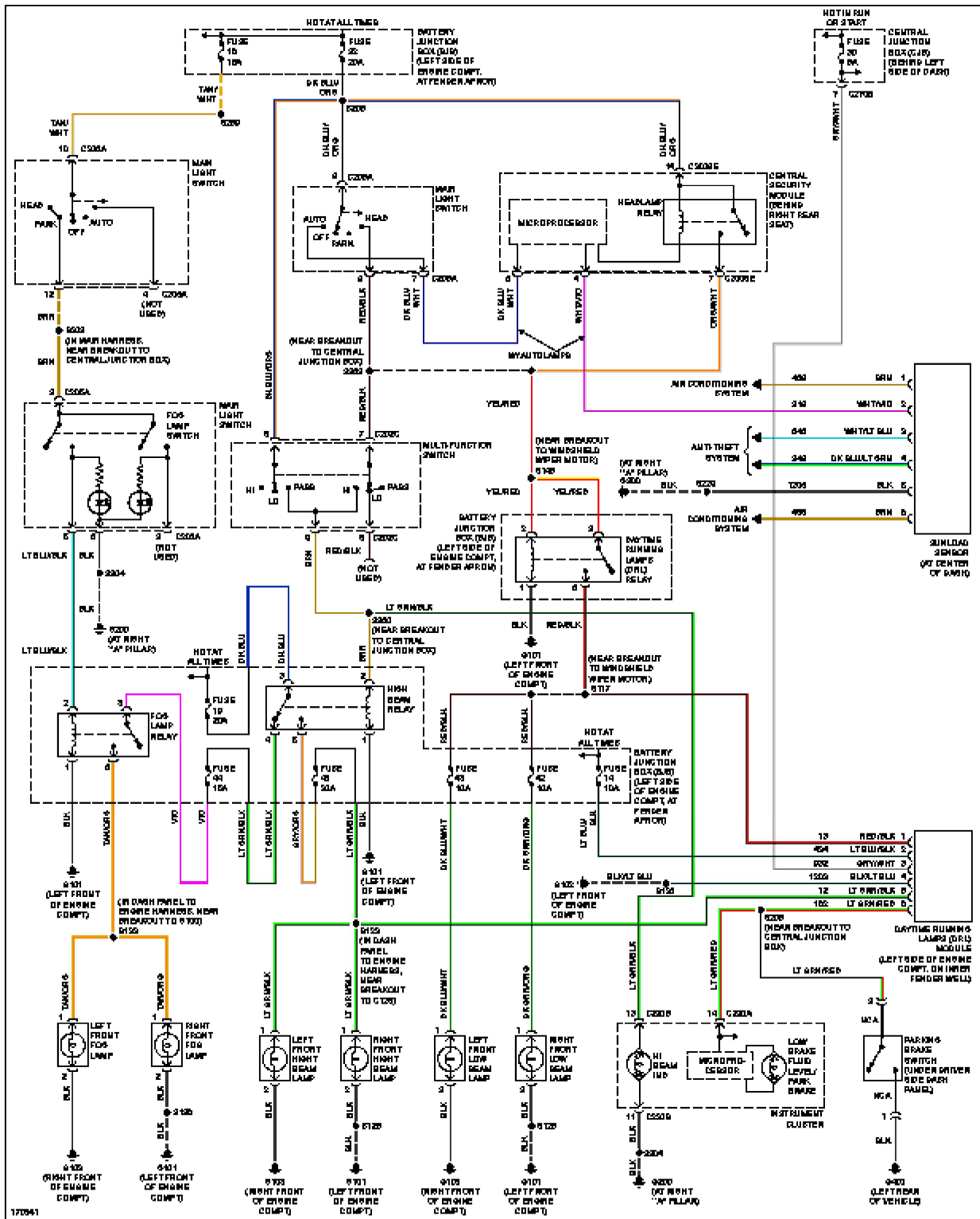

**Fig. 32: Headlights Circuit, W/ DRL**

# 2003 Ford Explorer

## SYSTEM WIRING DIAGRAMS 'Ford - Explorer

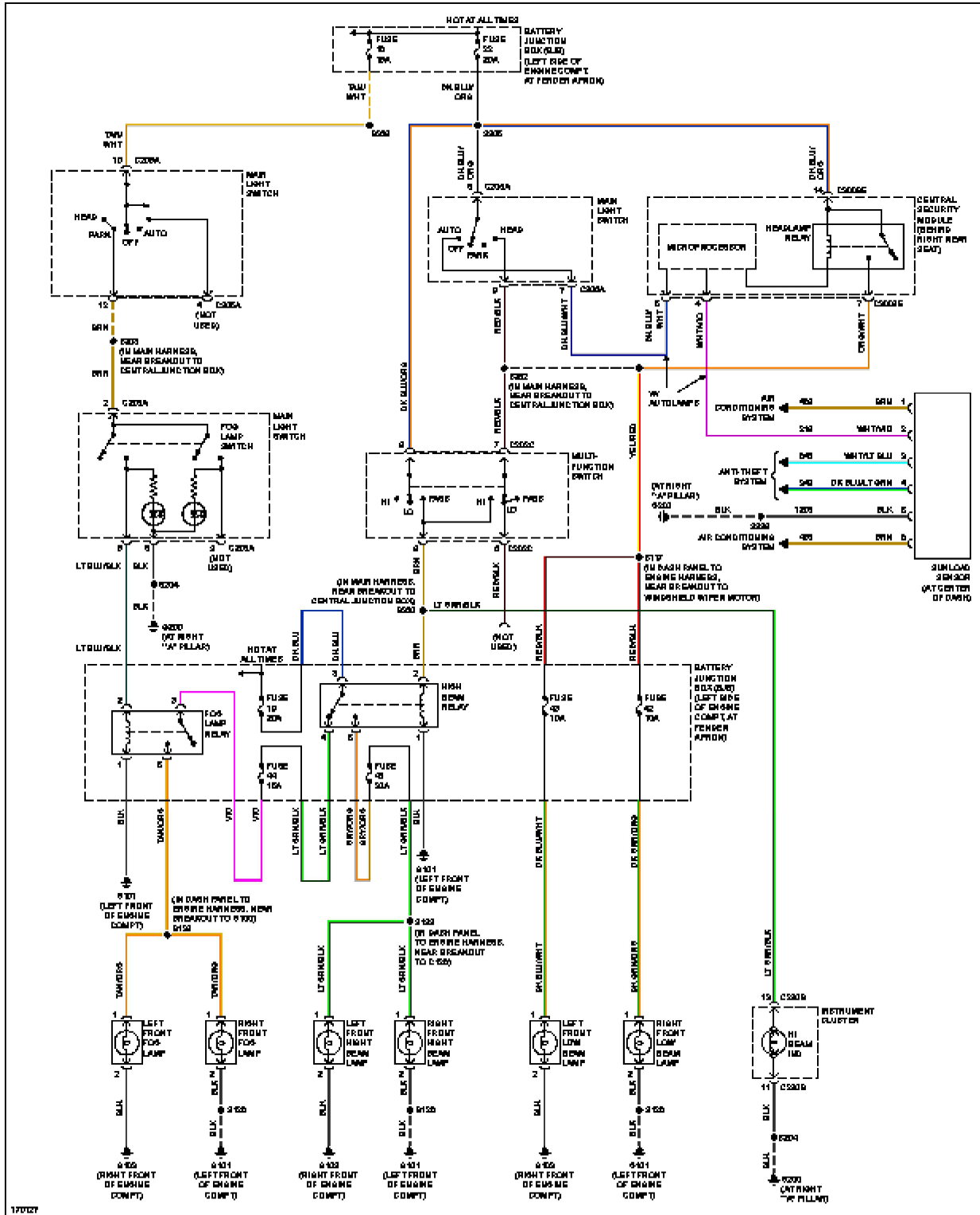

Fig. 33: Headlights Circuit, W/O DRL

**2003 Ford Explorer**

SYSTEM WIRING DIAGRAMS' 'Ford - Explorer

**HORN**

# 2003 Ford Explorer

## SYSTEM WIRING DIAGRAMS 'Ford - Explorer

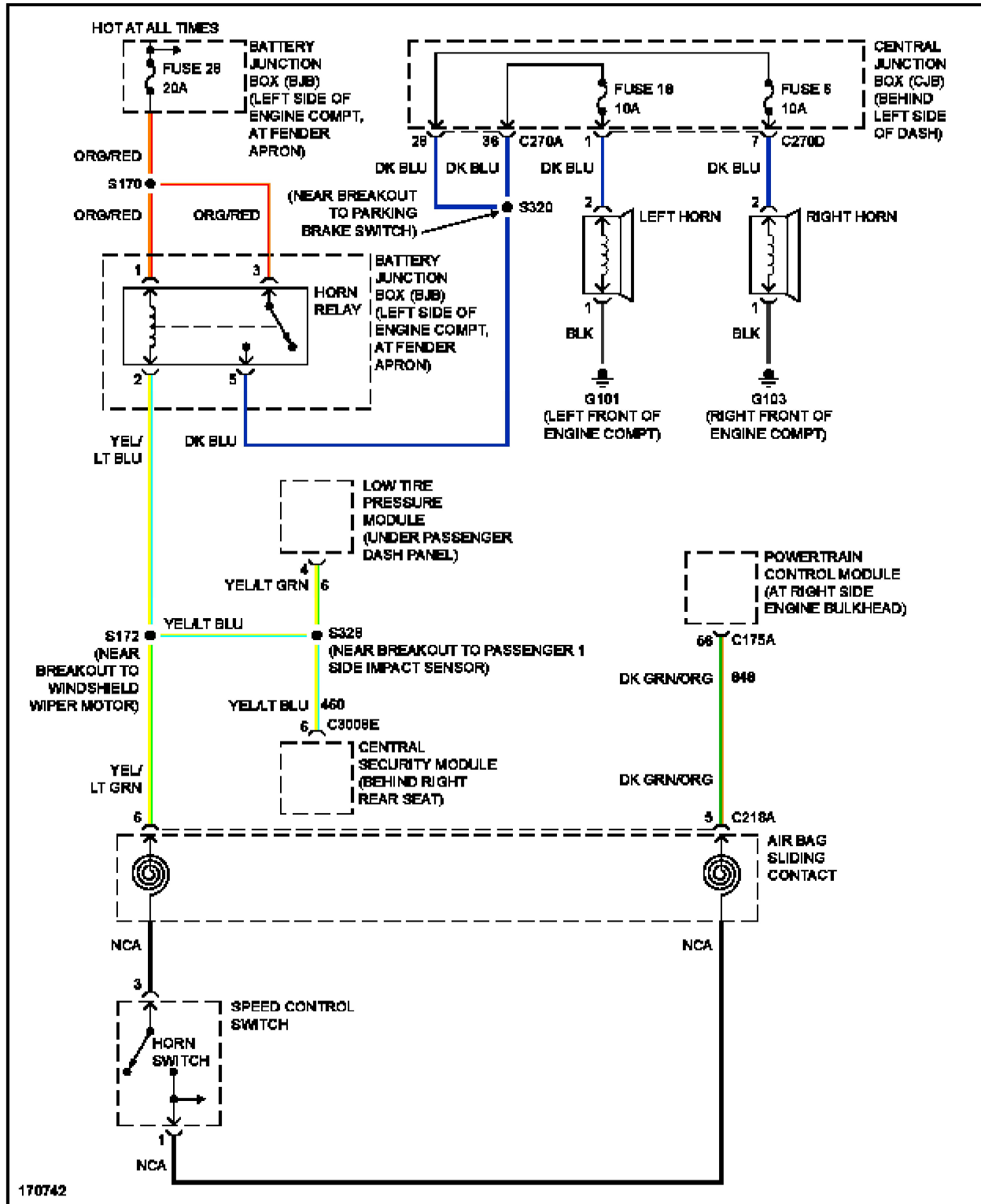

**Fig. 34: Horn Circuit**

## **INSTRUMENT CLUSTER**

# 2003 Ford Explorer

## SYSTEM WIRING DIAGRAMS 'Ford - Explorer

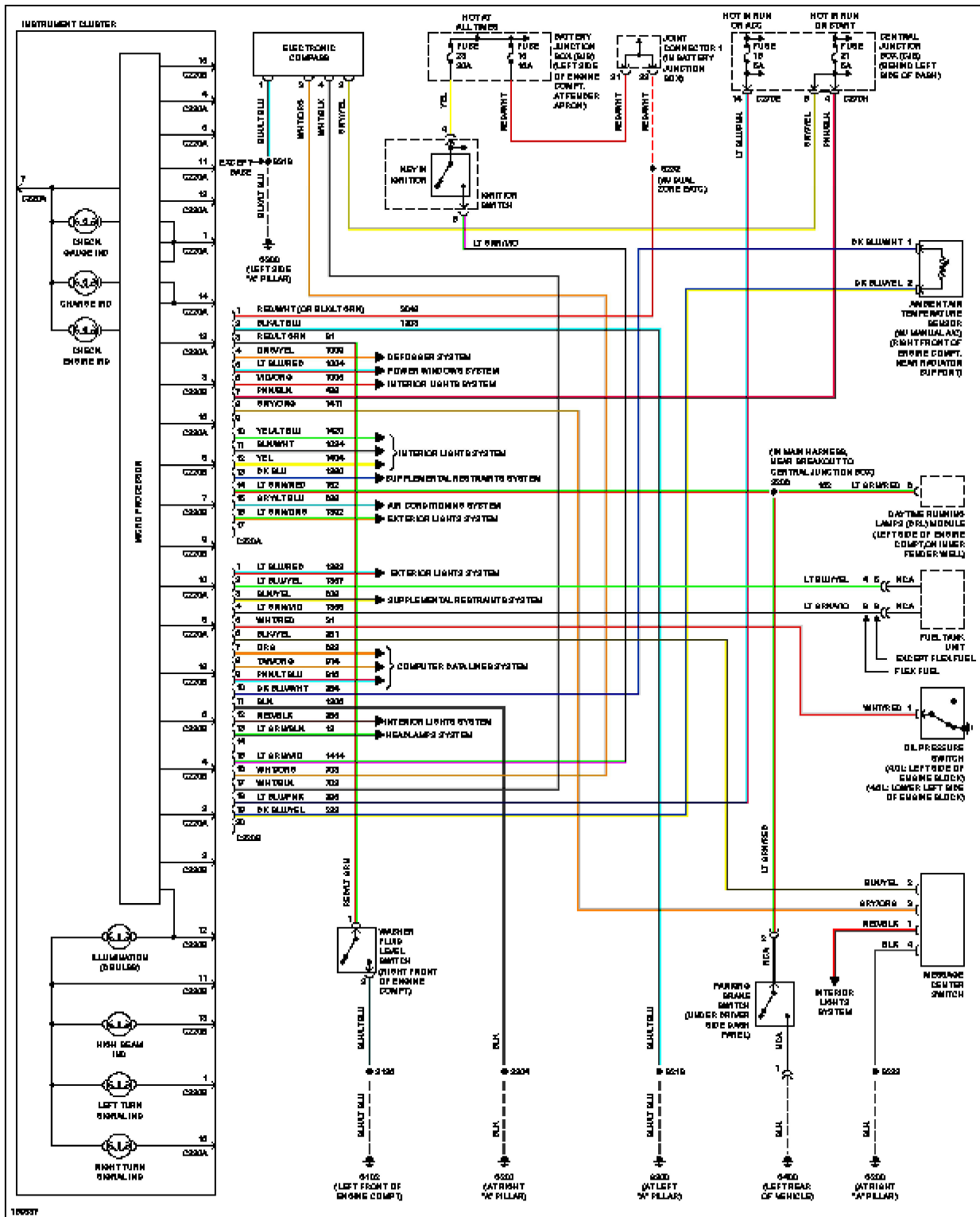
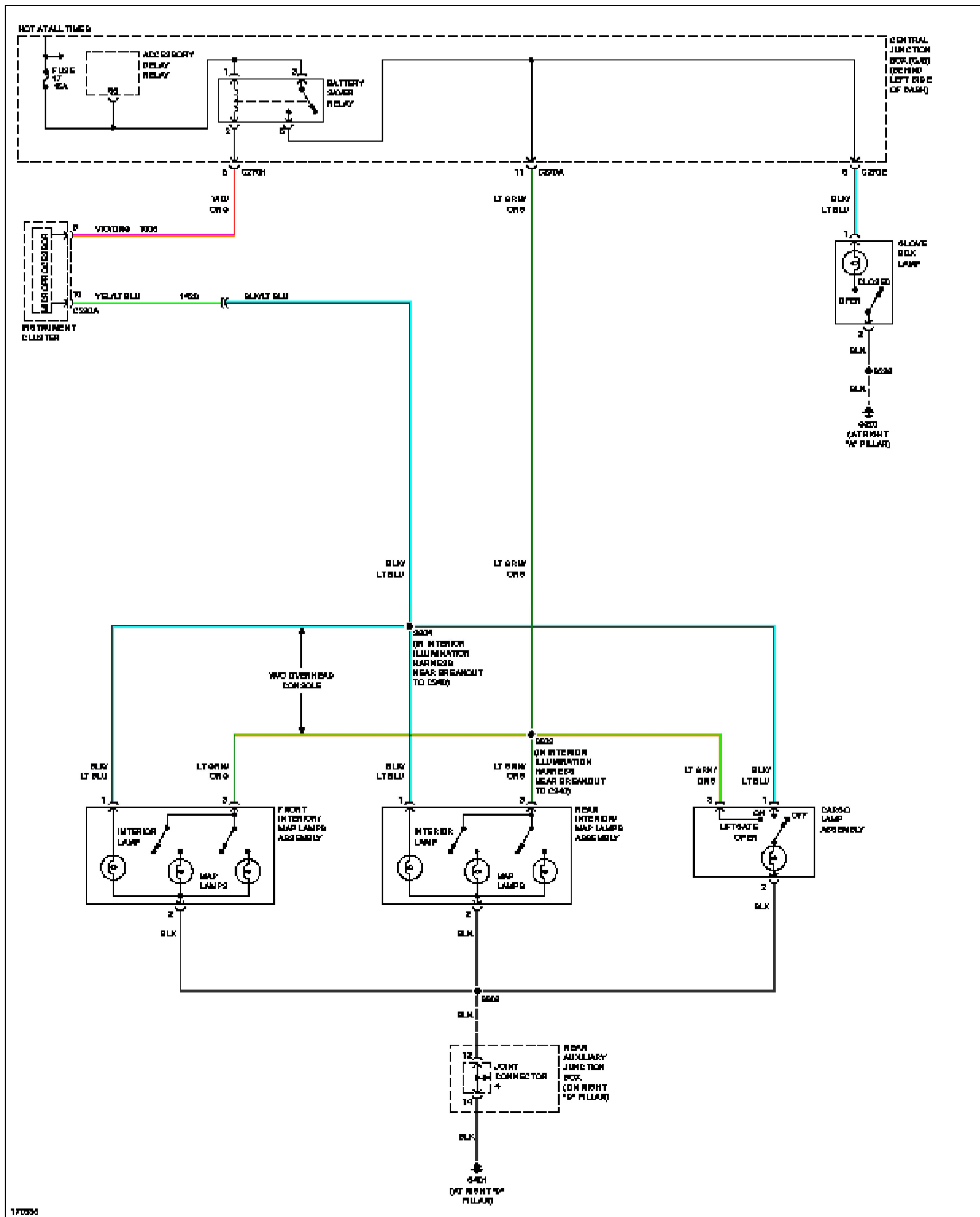

Fig. 35: Instrument Cluster Circuit

## **INTERIOR LIGHTS**

# 2003 Ford Explorer

## SYSTEM WIRING DIAGRAMS 'Ford - Explorer



**Fig. 36: Courtesy Lamps Circuit, Base**



# 2003 Ford Explorer

## SYSTEM WIRING DIAGRAMS 'Ford - Explorer

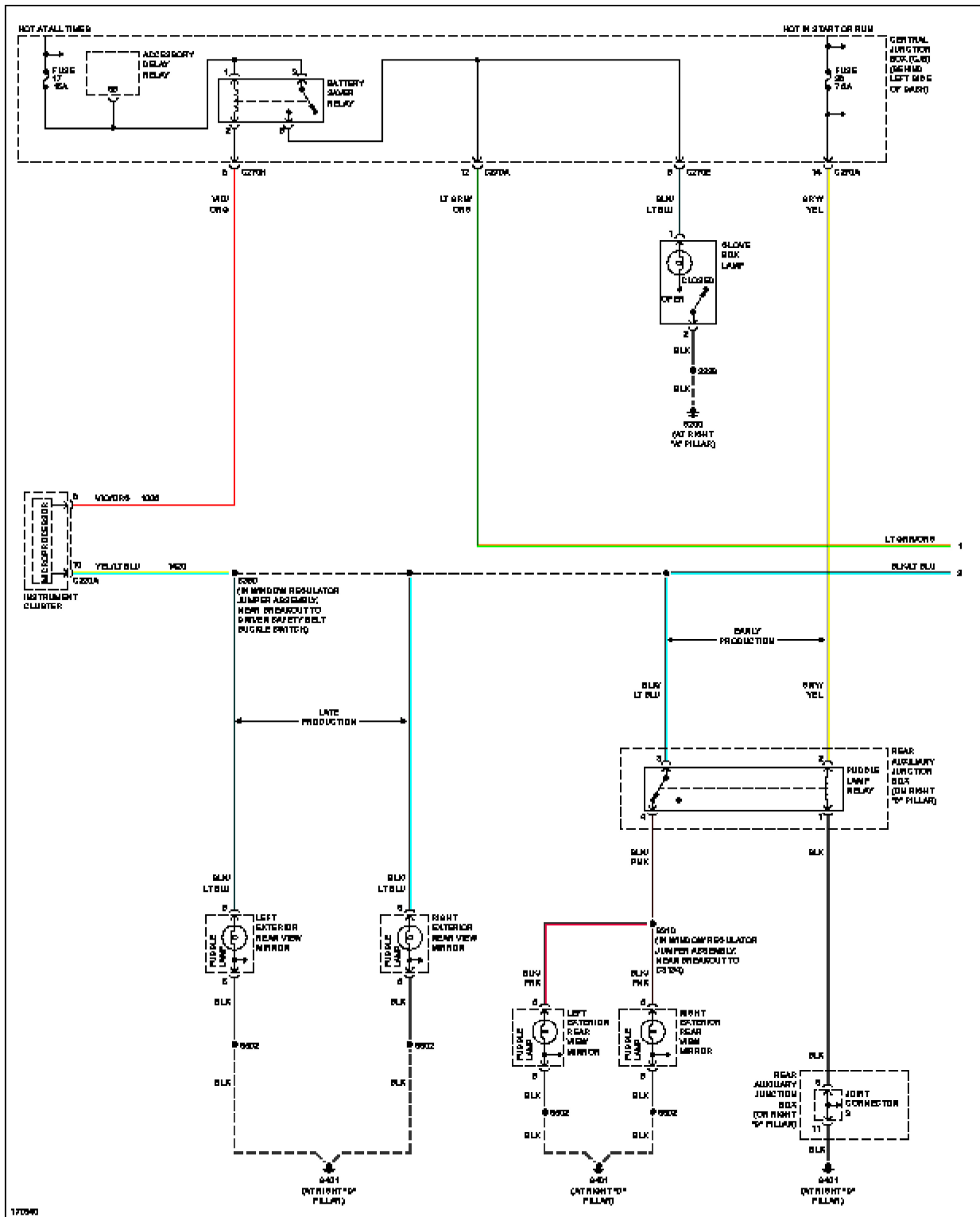
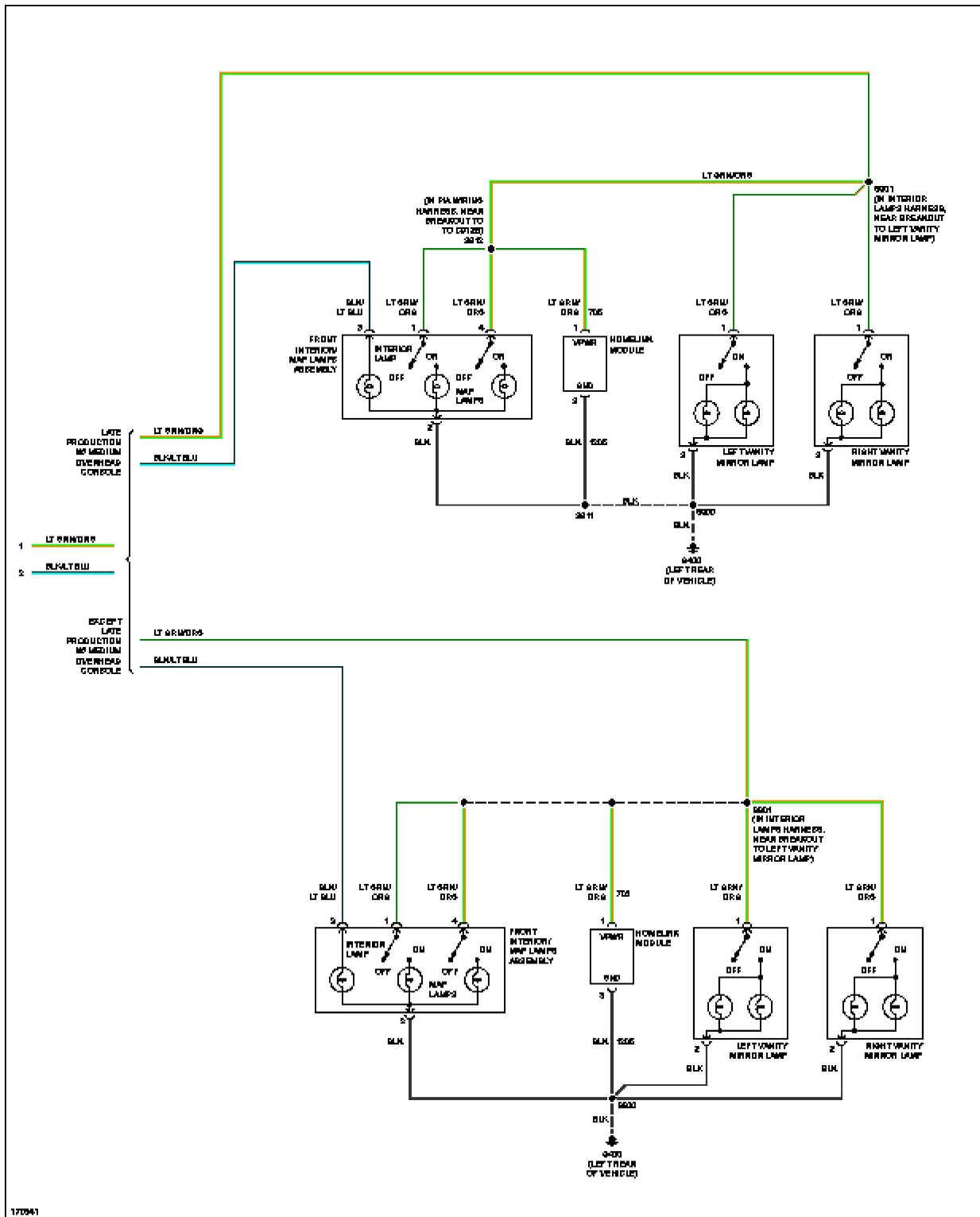

Fig. 37: Courtesy Lamps Circuit, Except Base (1 of 2)

# 2003 Ford Explorer

## SYSTEM WIRING DIAGRAMS 'Ford - Explorer



**Fig. 38: Courtesy Lamps Circuit, Except Base (2 of 2)**

# 2003 Ford Explorer

## SYSTEM WIRING DIAGRAMS 'Ford - Explorer

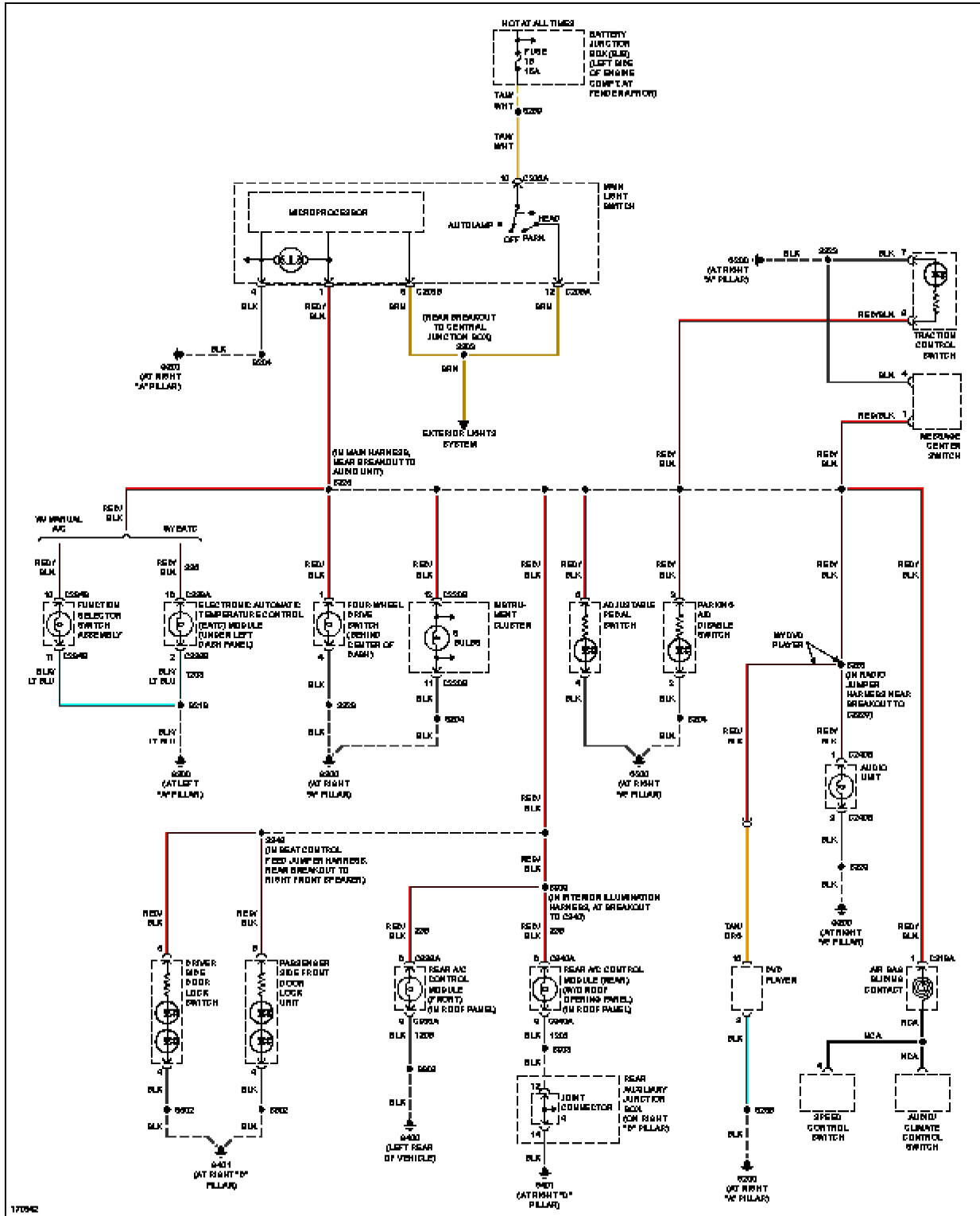
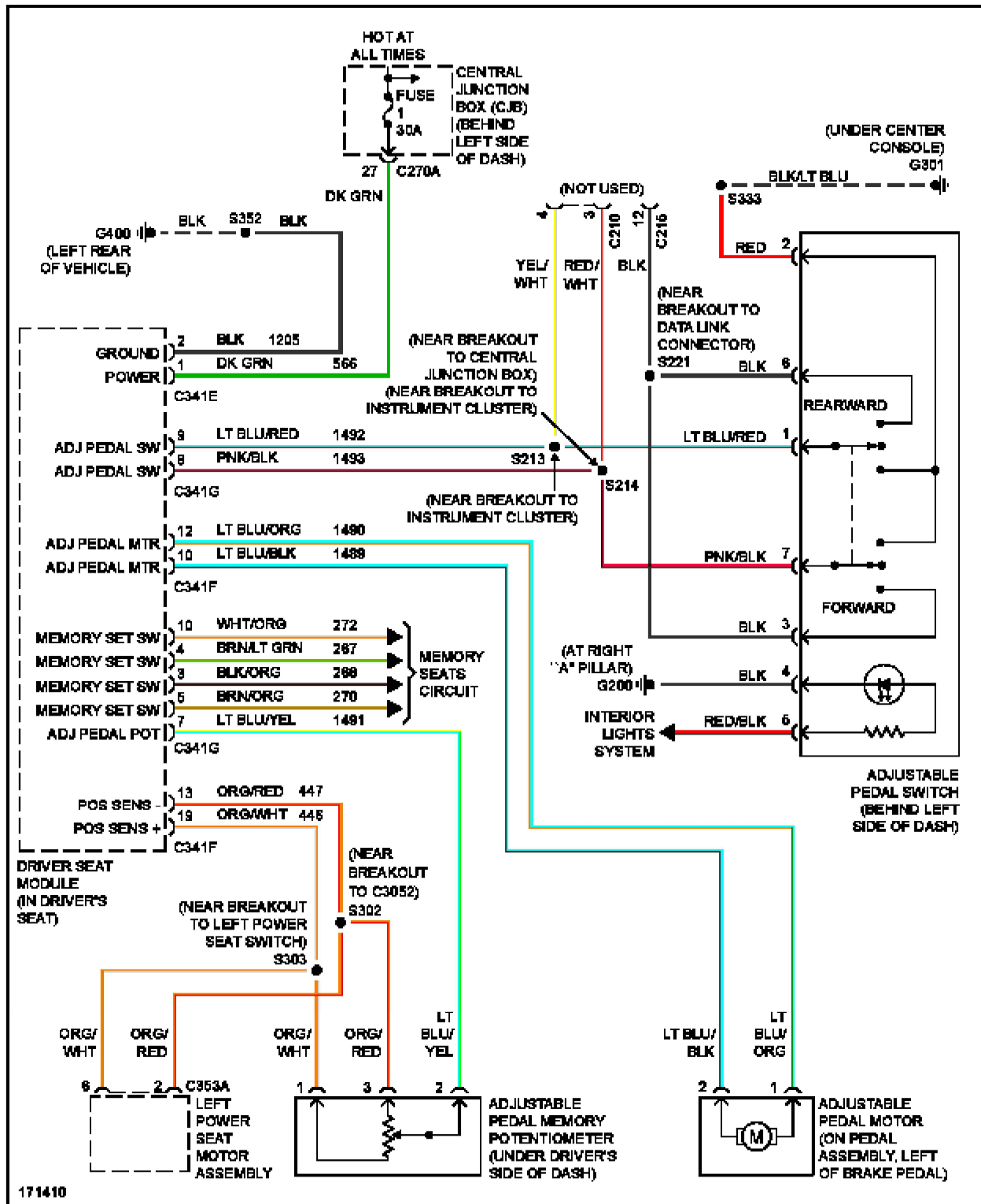

Fig. 39: Instrument Illumination Circuit

## **MEMORY SYSTEMS**

# 2003 Ford Explorer

## SYSTEM WIRING DIAGRAMS 'Ford - Explorer



**Fig. 40: Adjustable Pedal Circuit**

# 2003 Ford Explorer

## SYSTEM WIRING DIAGRAMS 'Ford - Explorer

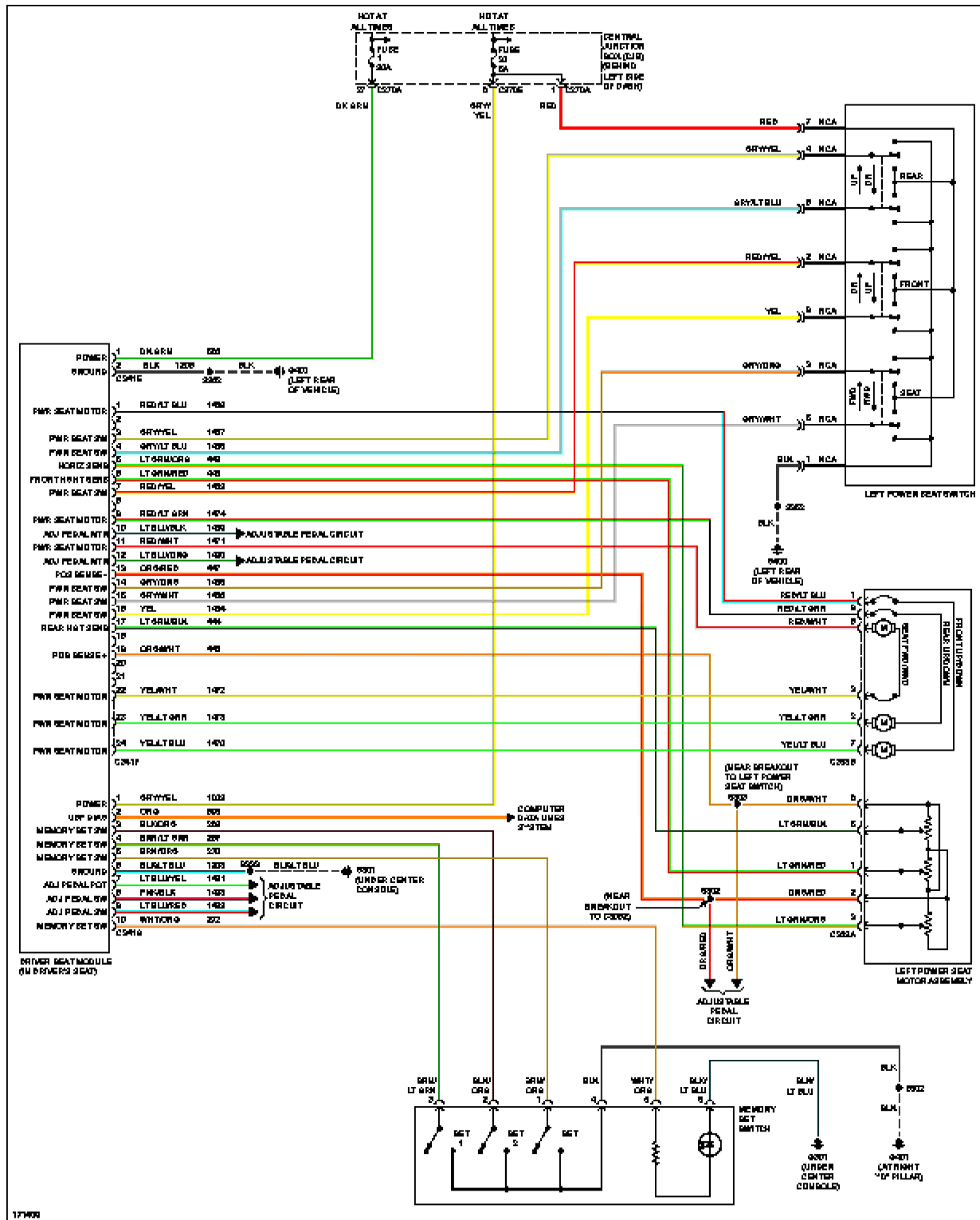

Fig. 41: Driver's Memory Seat Circuit

## 2003 Ford Explorer

SYSTEM WIRING DIAGRAMS' 'Ford - Explorer

### NAVIGATION

# 2003 Ford Explorer

## SYSTEM WIRING DIAGRAMS 'Ford - Explorer

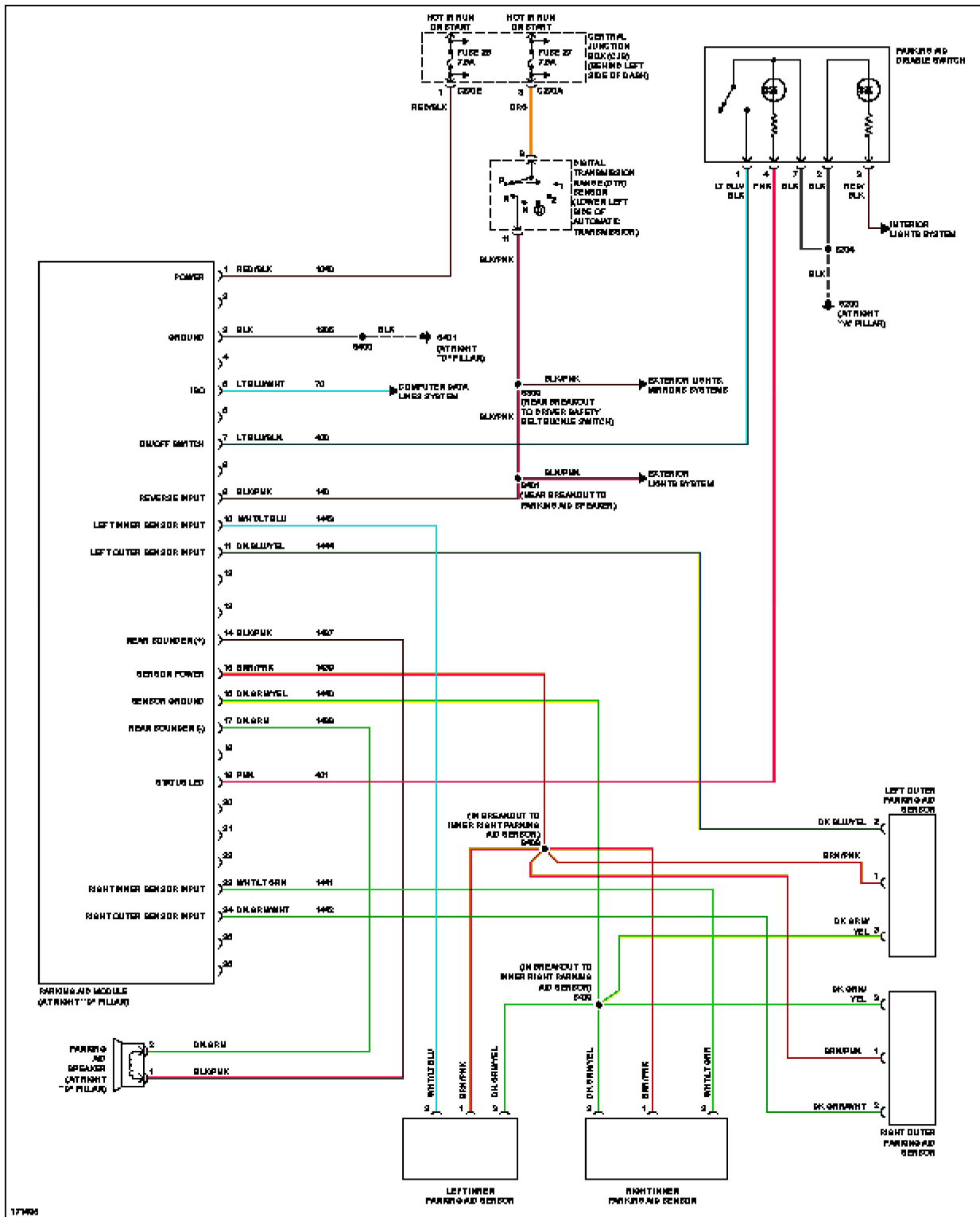

Fig. 42: Navigation Circuit



## **POWER DISTRIBUTION**

# 2003 Ford Explorer

## SYSTEM WIRING DIAGRAMS 'Ford - Explorer

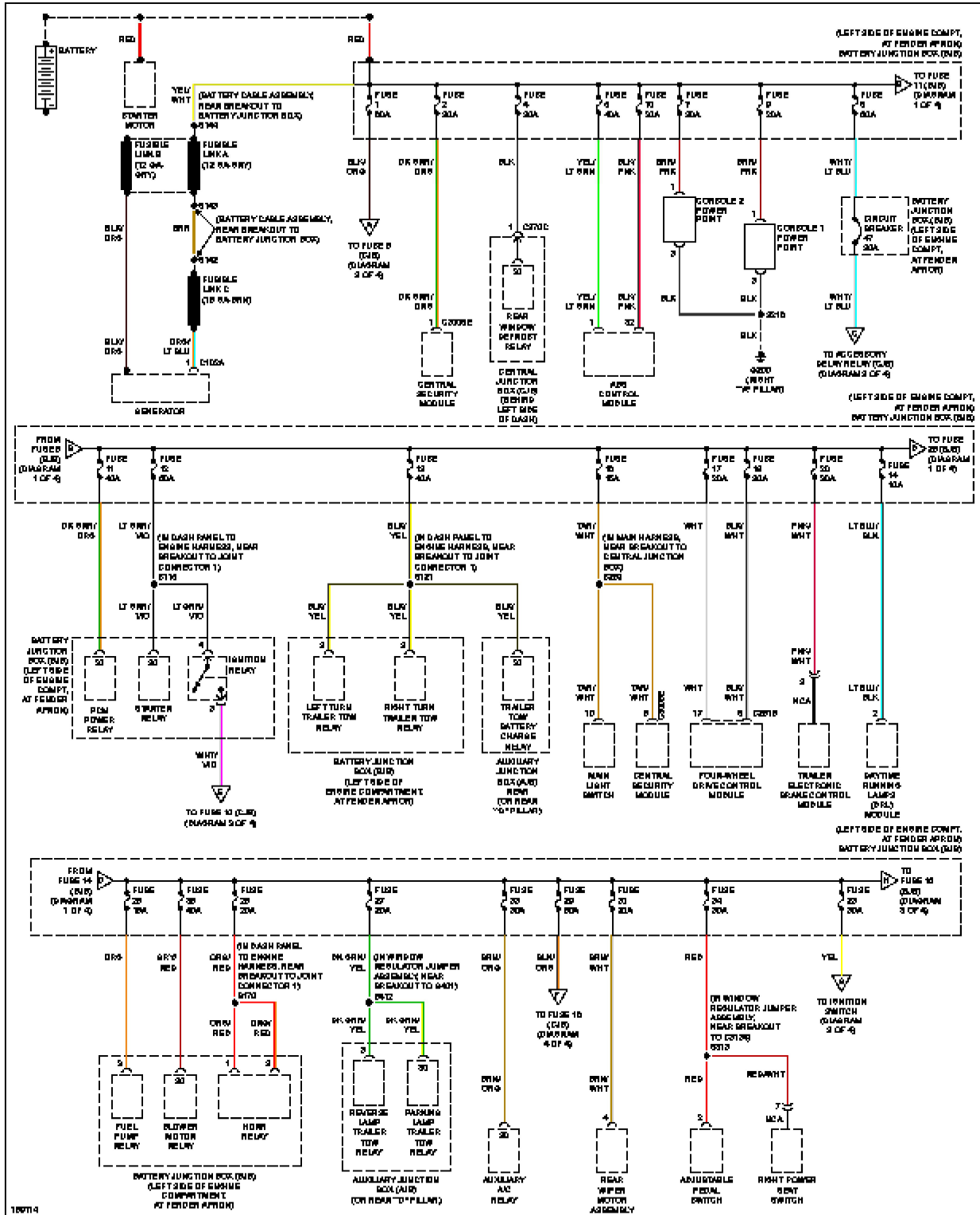

Fig. 43: Power Distribution Circuit (1 of 4)

# 2003 Ford Explorer

## SYSTEM WIRING DIAGRAMS 'Ford - Explorer

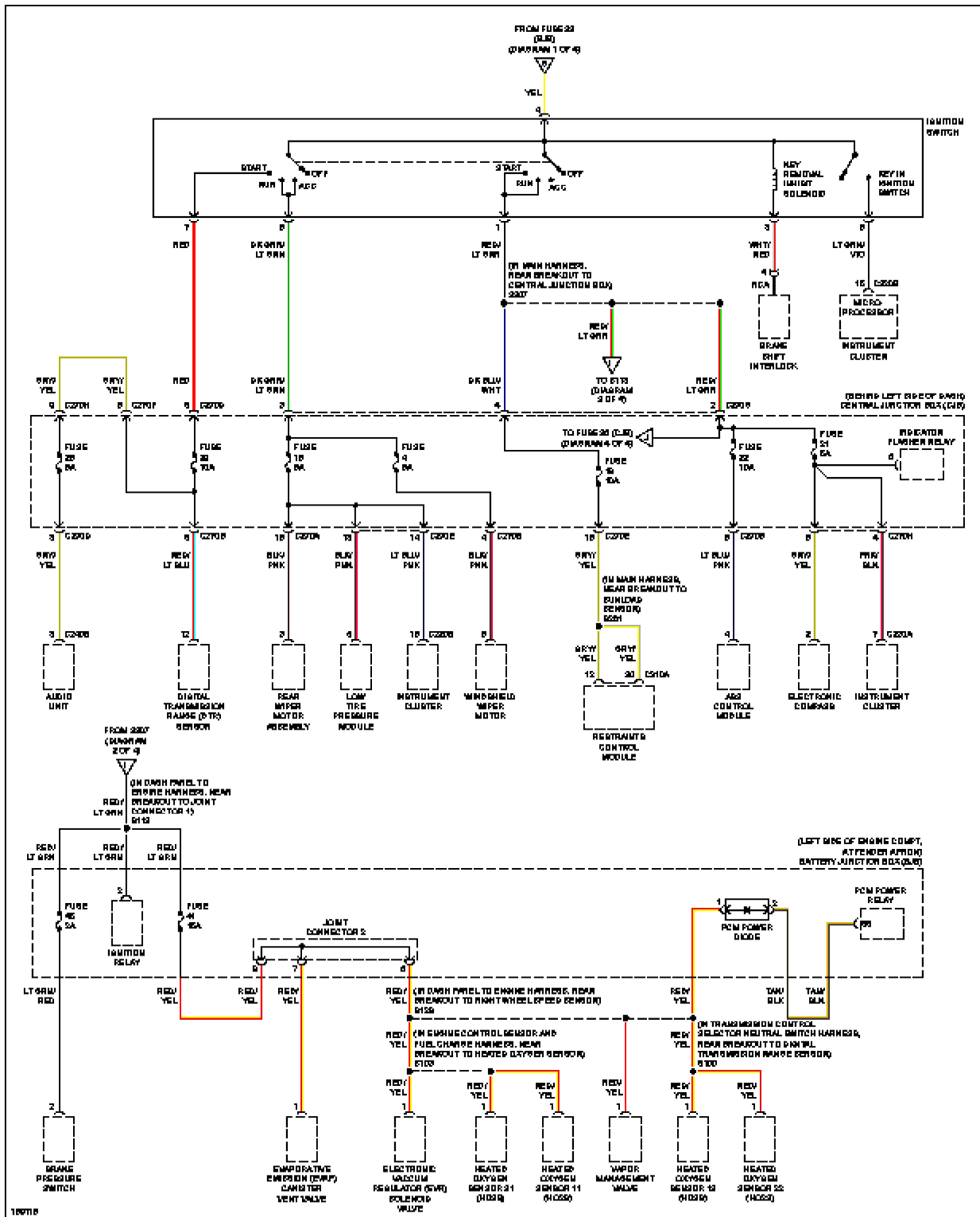

Fig. 44: Power Distribution Circuit (2 of 4)

# 2003 Ford Explorer

## SYSTEM WIRING DIAGRAMS 'Ford - Explorer

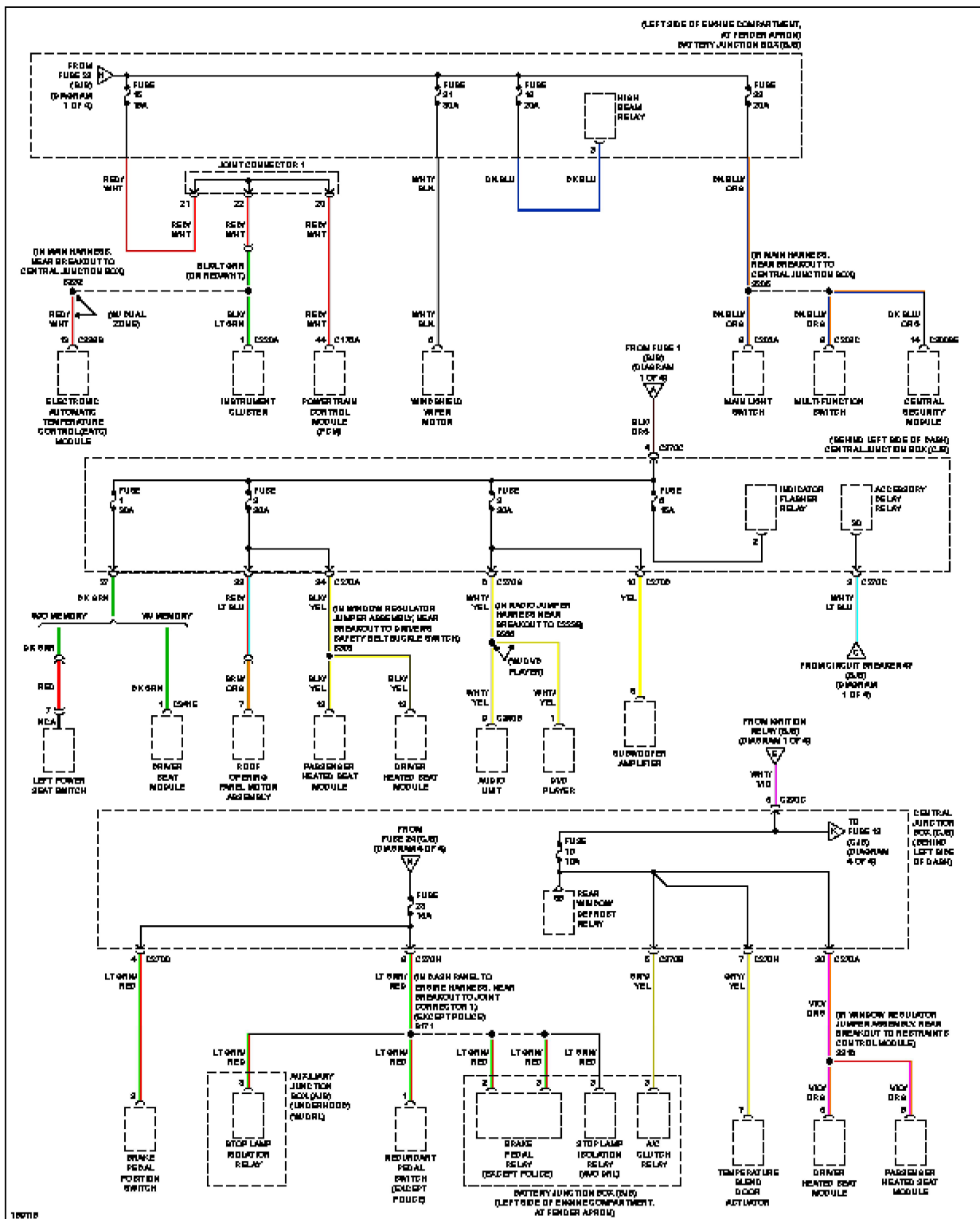
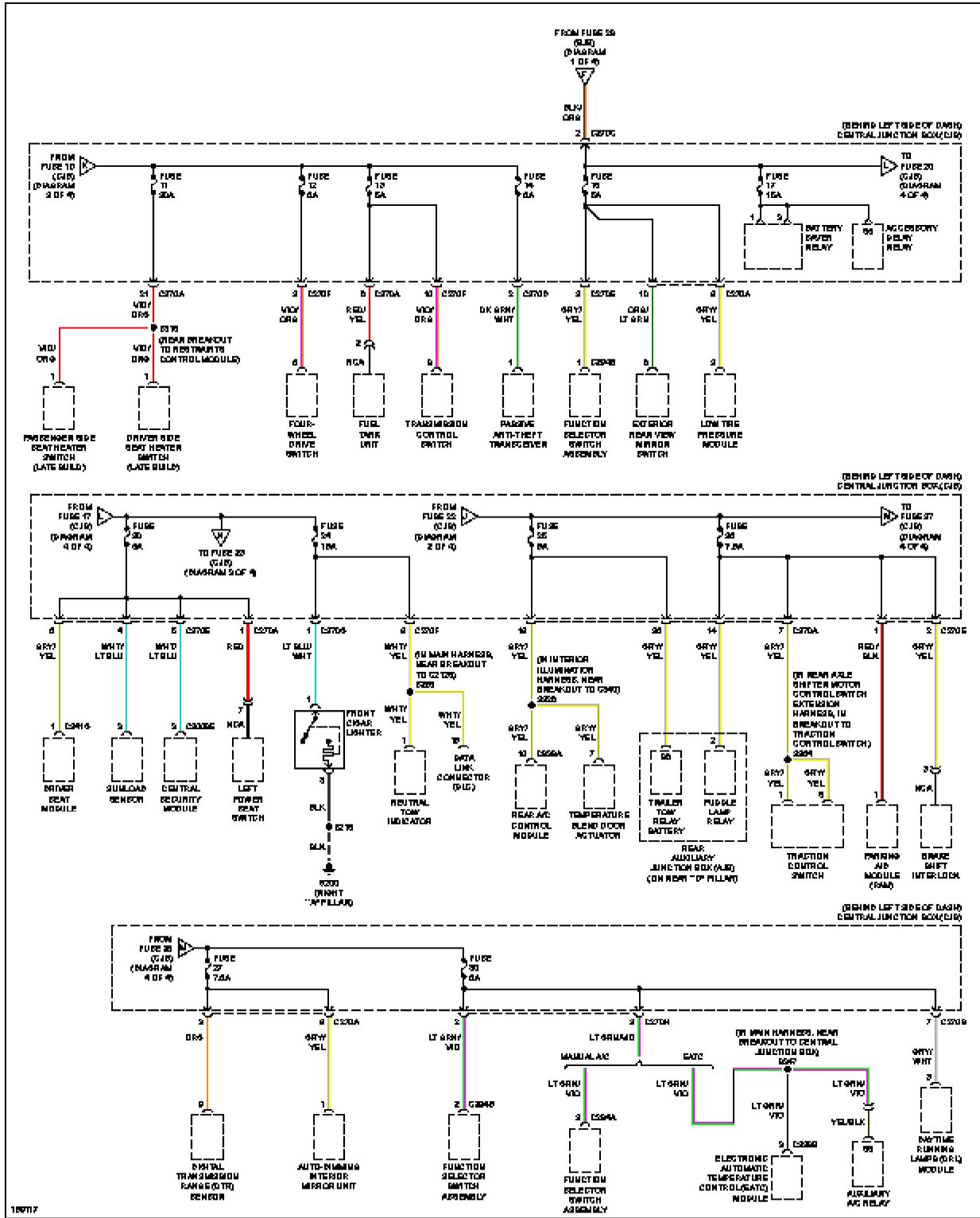

Fig. 45: Power Distribution Circuit (3 of 4)

# 2003 Ford Explorer

## SYSTEM WIRING DIAGRAMS 'Ford - Explorer

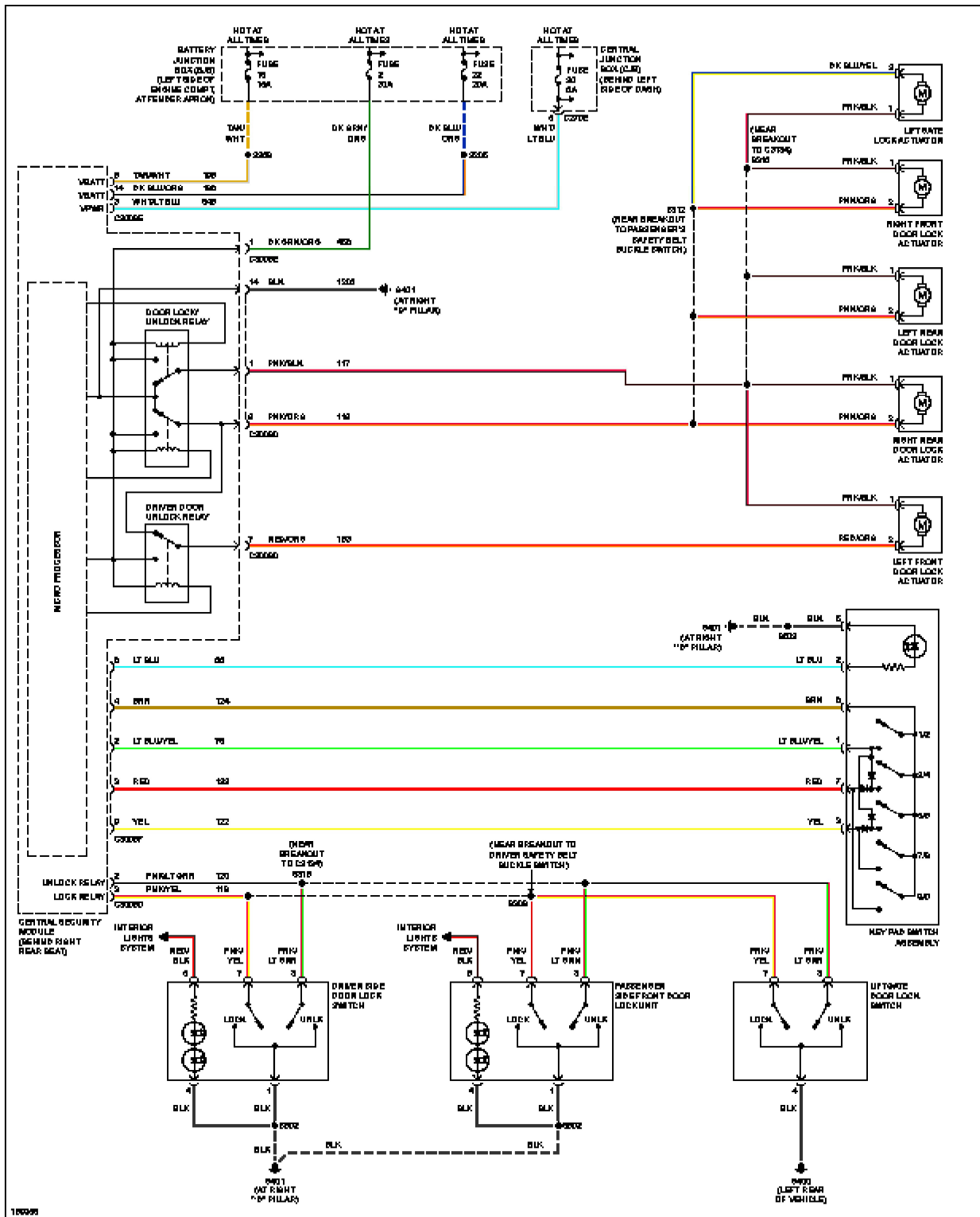

**Fig. 46: Power Distribution Circuit (4 of 4)**

## **POWER DOOR LOCKS**

# 2003 Ford Explorer

## SYSTEM WIRING DIAGRAMS 'Ford - Explorer



**Fig. 47: Power Door Locks Circuit**

## **POWER MIRRORS**



# 2003 Ford Explorer

## SYSTEM WIRING DIAGRAMS 'Ford - Explorer

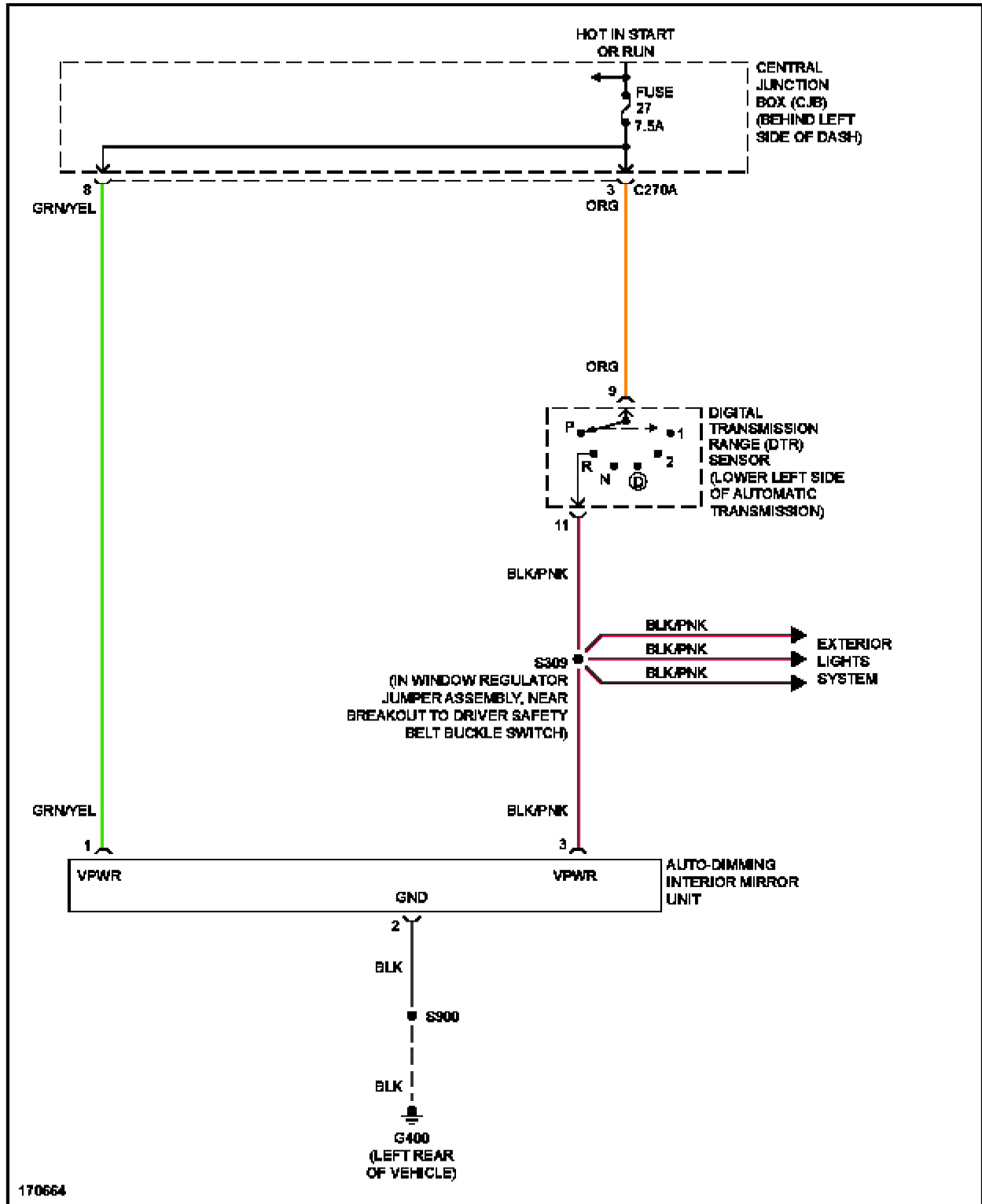

**Fig. 48: Electronic Day/Night Mirror Circuit**

# 2003 Ford Explorer

## SYSTEM WIRING DIAGRAMS 'Ford - Explorer

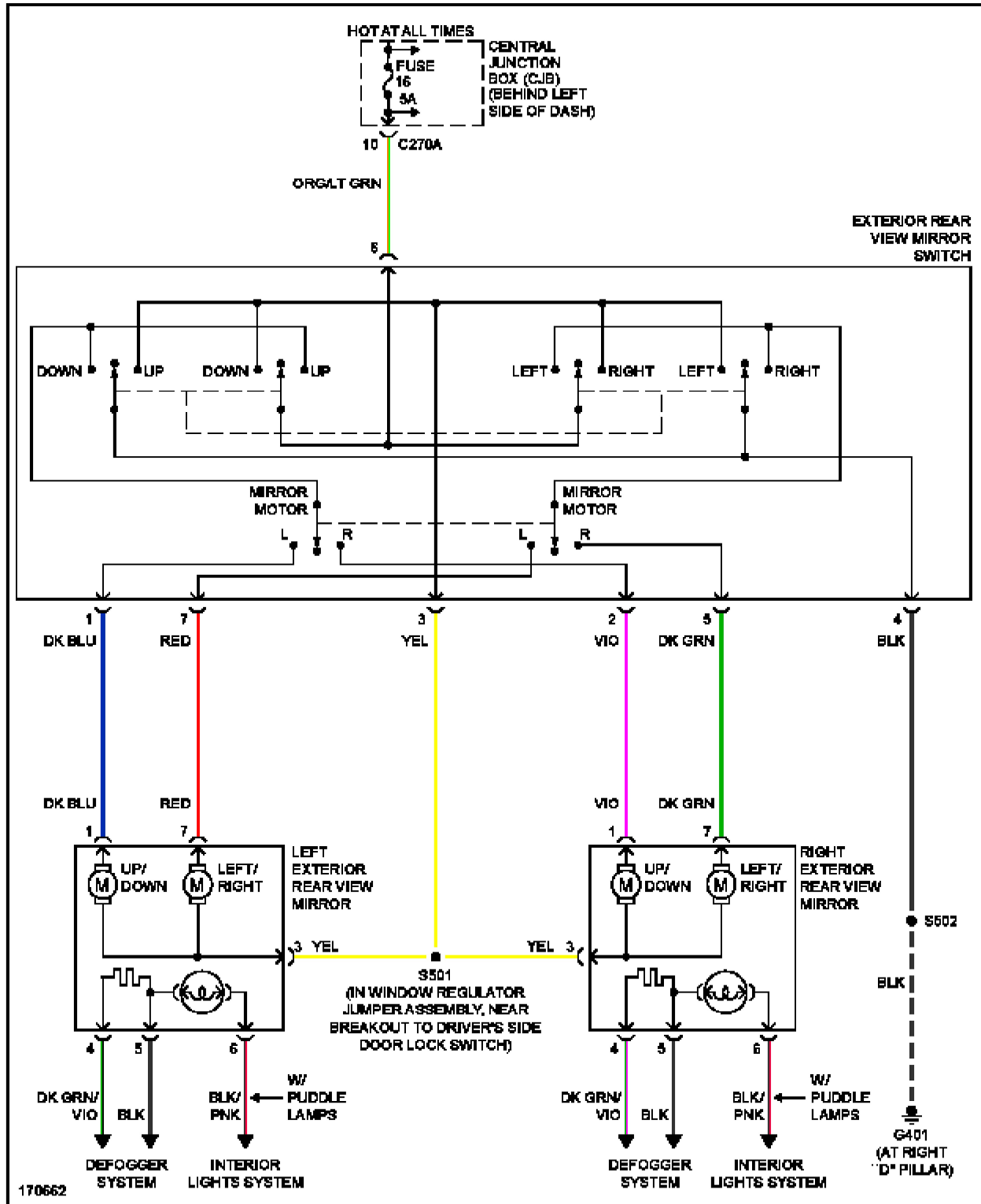
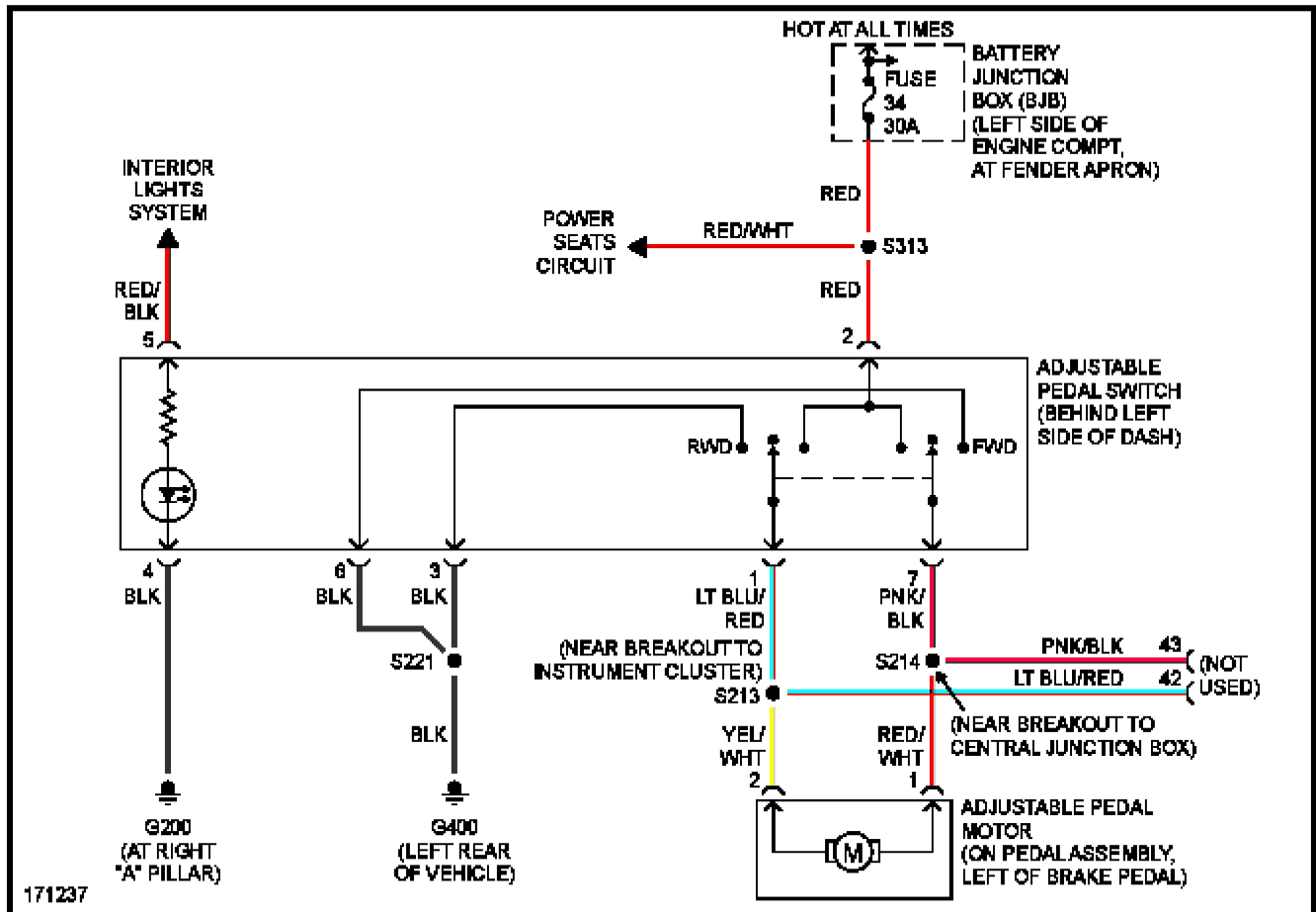

**Fig. 49: Power Mirrors Circuit**

## **POWER SEATS**

# 2003 Ford Explorer

## SYSTEM WIRING DIAGRAMS 'Ford - Explorer



**Fig. 50: Adjustable Pedal Circuit**

# 2003 Ford Explorer

## SYSTEM WIRING DIAGRAMS 'Ford - Explorer

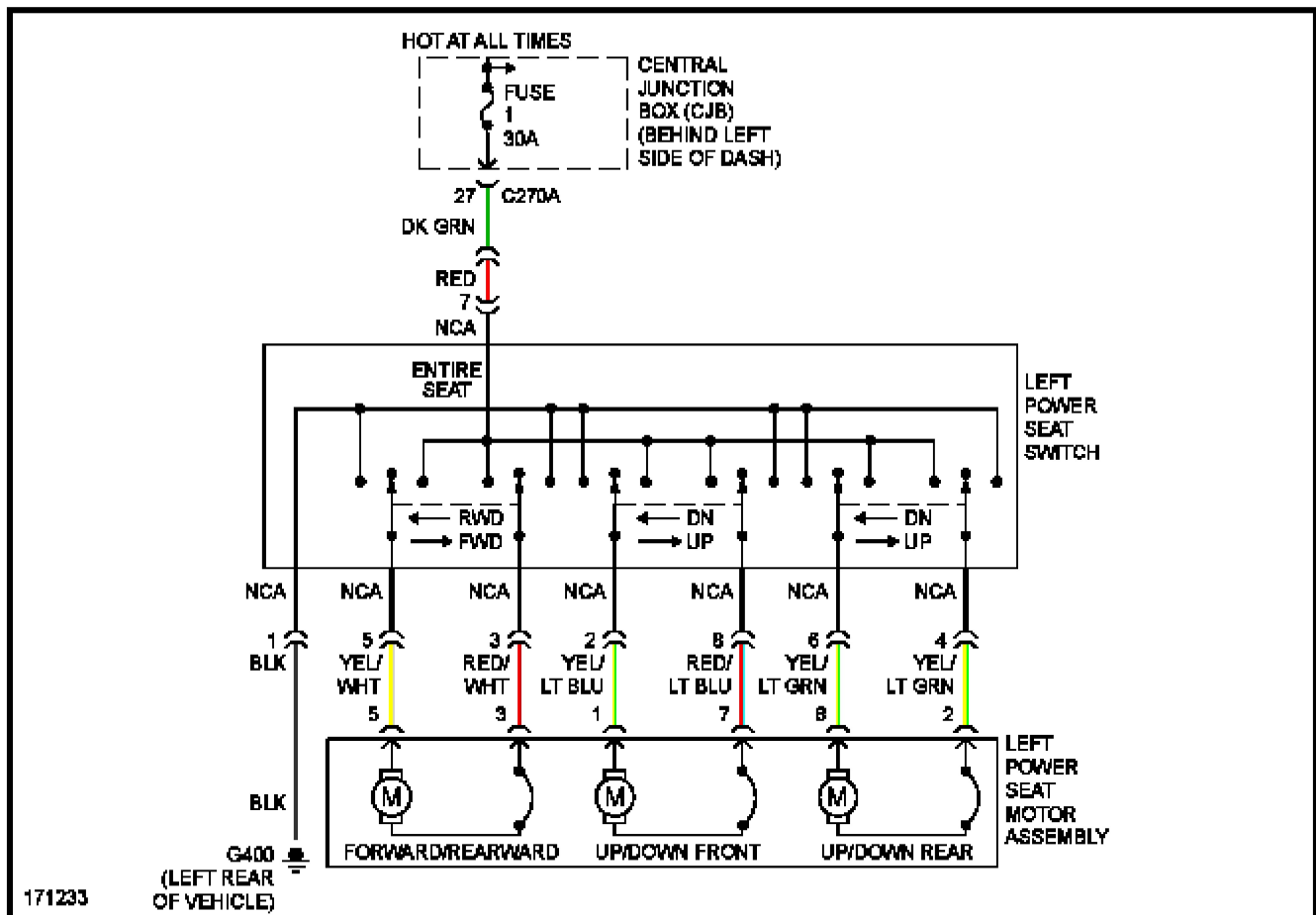

**Fig. 51: Driver Power Seat Circuit**

# 2003 Ford Explorer

## SYSTEM WIRING DIAGRAMS 'Ford - Explorer

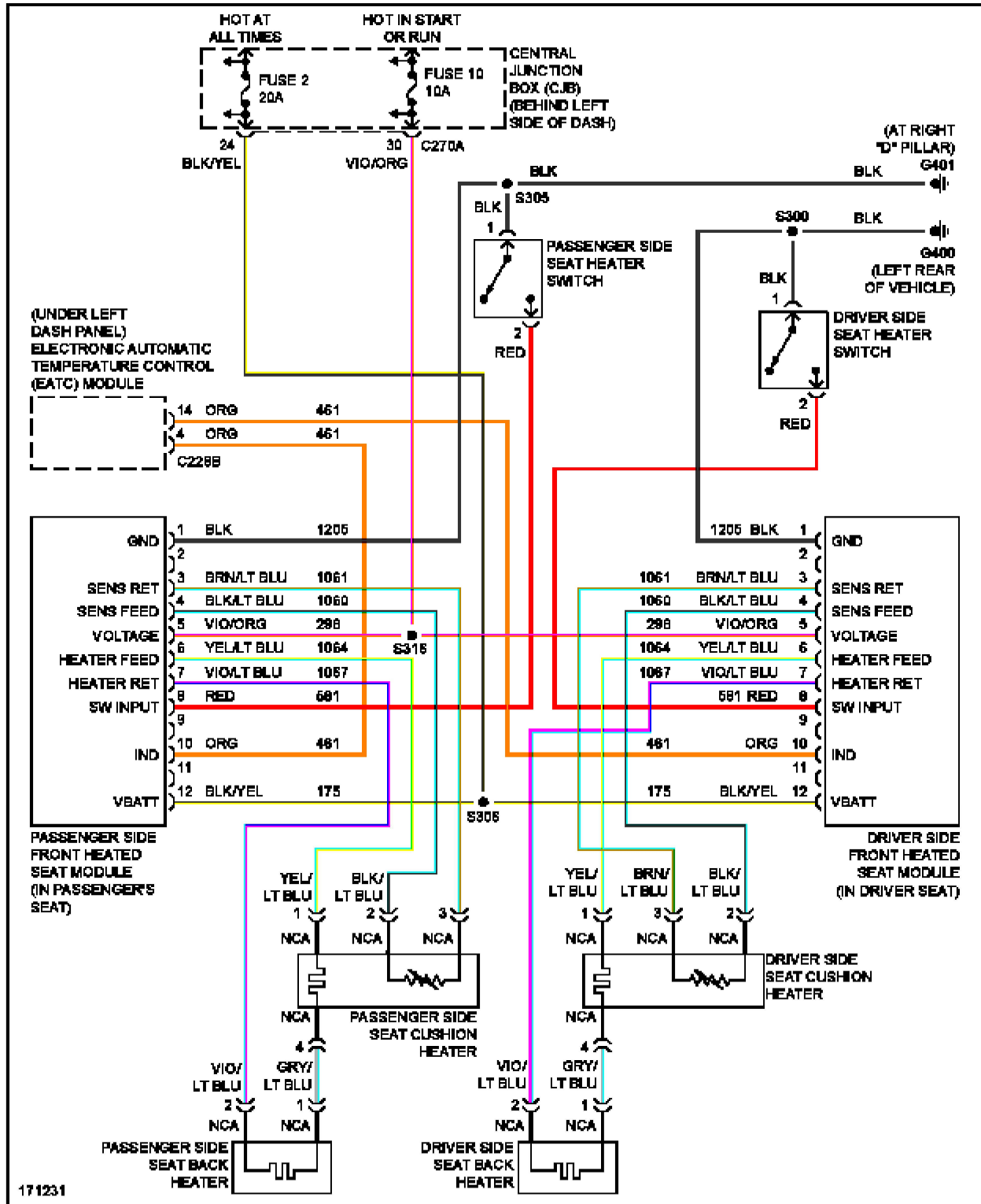

**Fig. 52: Heated Seats Circuit, Early Production**

# 2003 Ford Explorer

## SYSTEM WIRING DIAGRAMS 'Ford - Explorer

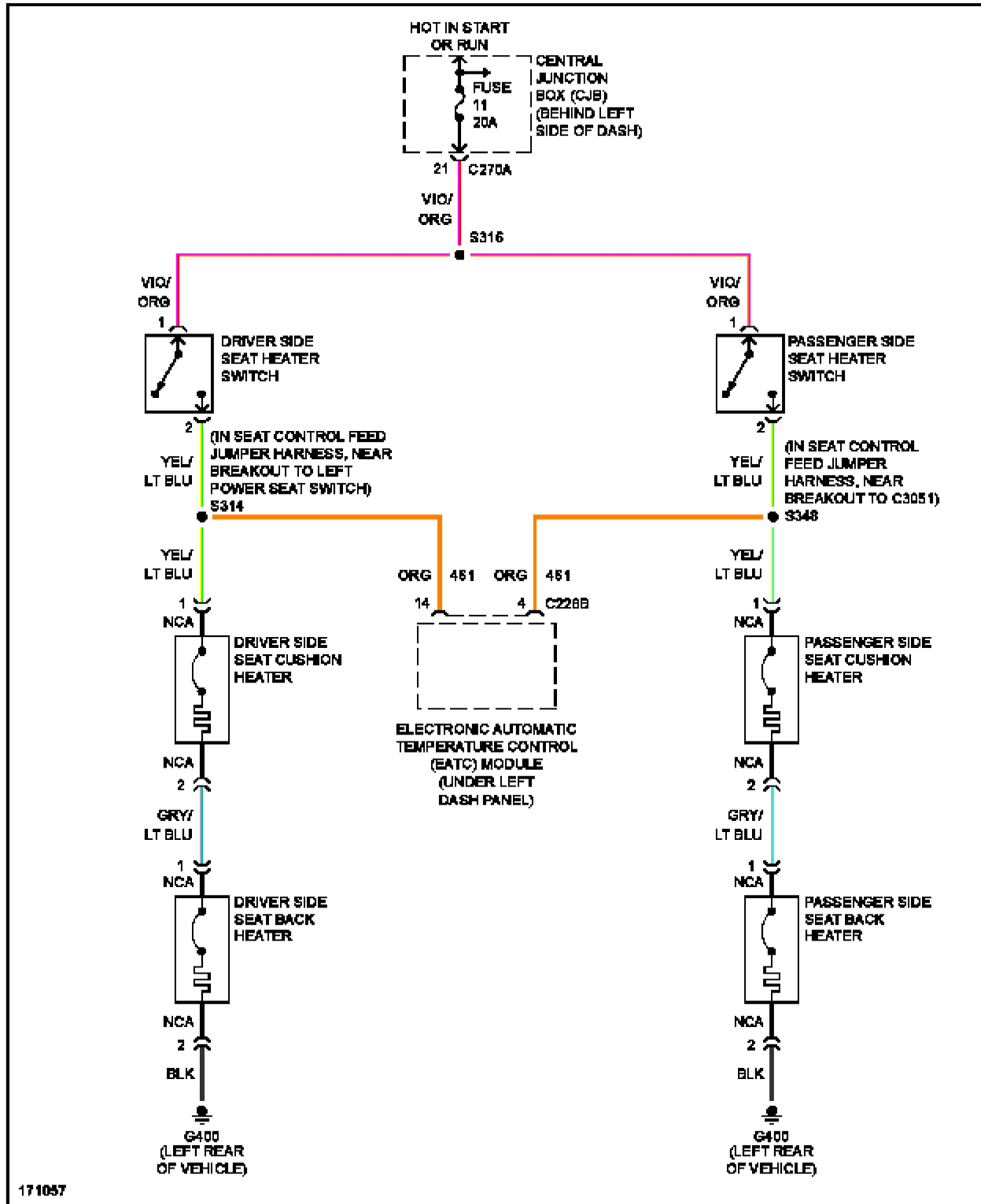

**Fig. 53: Heated Seats Circuit, Late Production**

# 2003 Ford Explorer

## SYSTEM WIRING DIAGRAMS 'Ford - Explorer

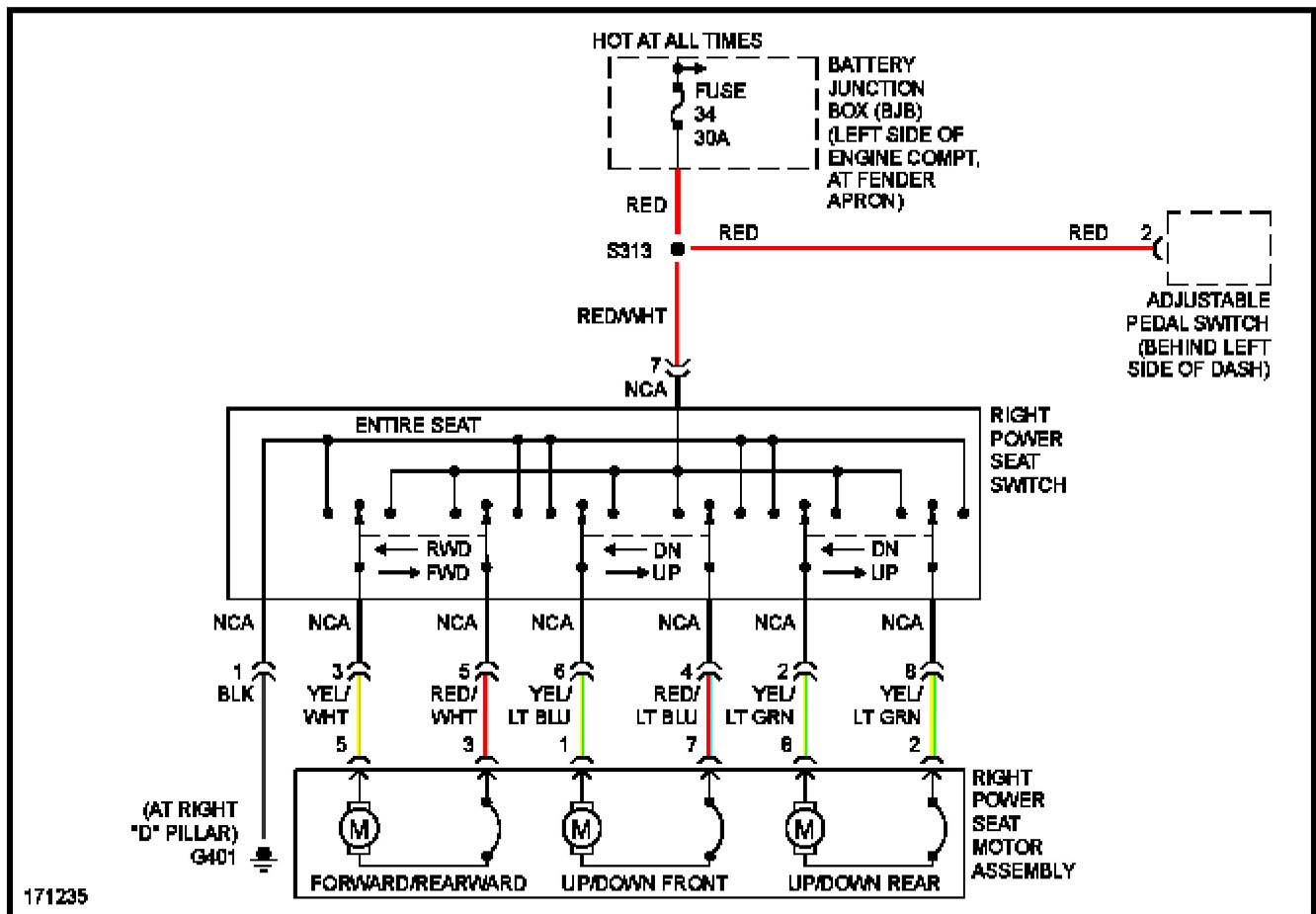

**Fig. 54: Passenger Power Seat Circuit**



**2003 Ford Explorer**

SYSTEM WIRING DIAGRAMS' 'Ford - Explorer

**POWER TOP/SUNROOF**

# 2003 Ford Explorer

## SYSTEM WIRING DIAGRAMS 'Ford - Explorer

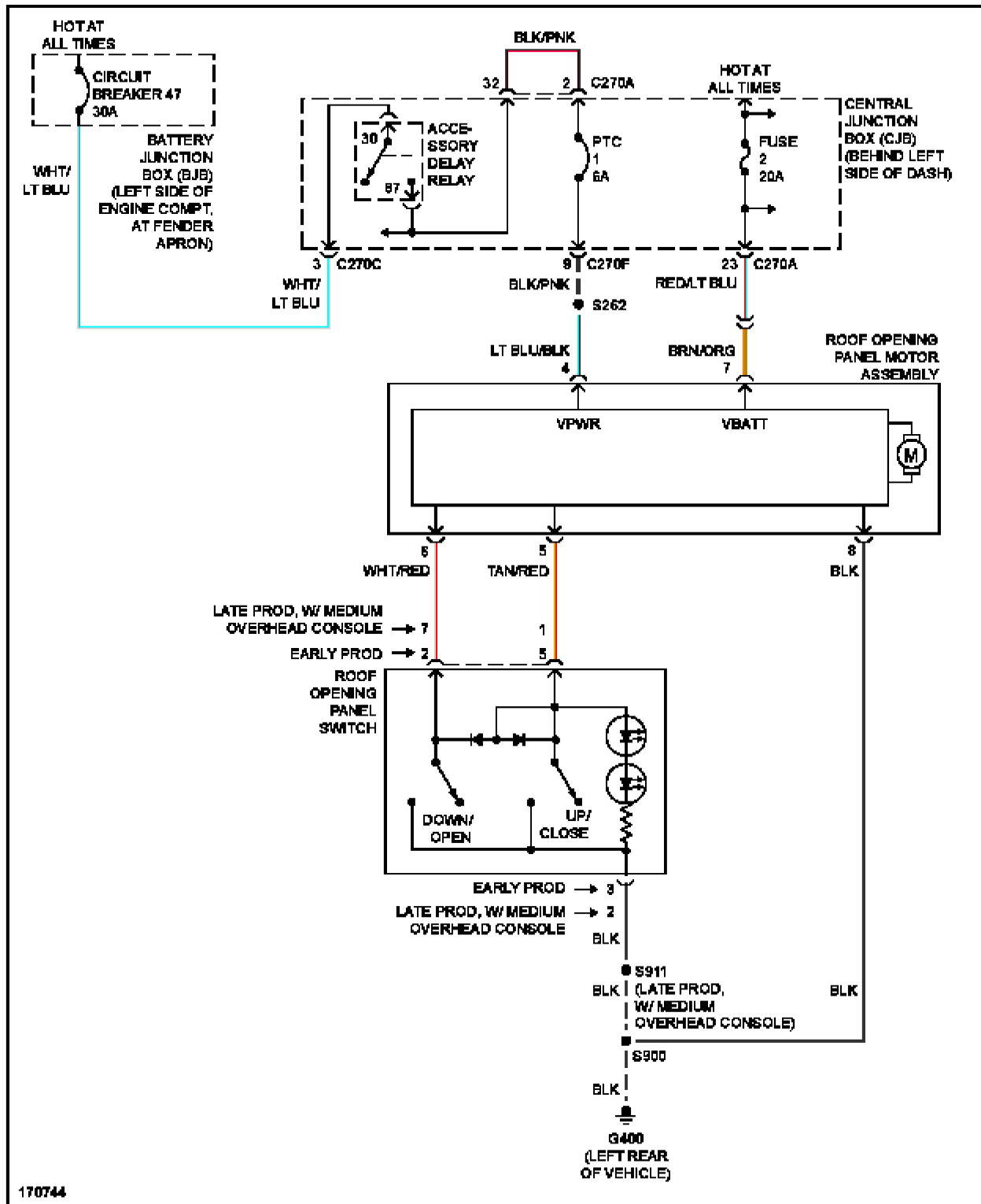
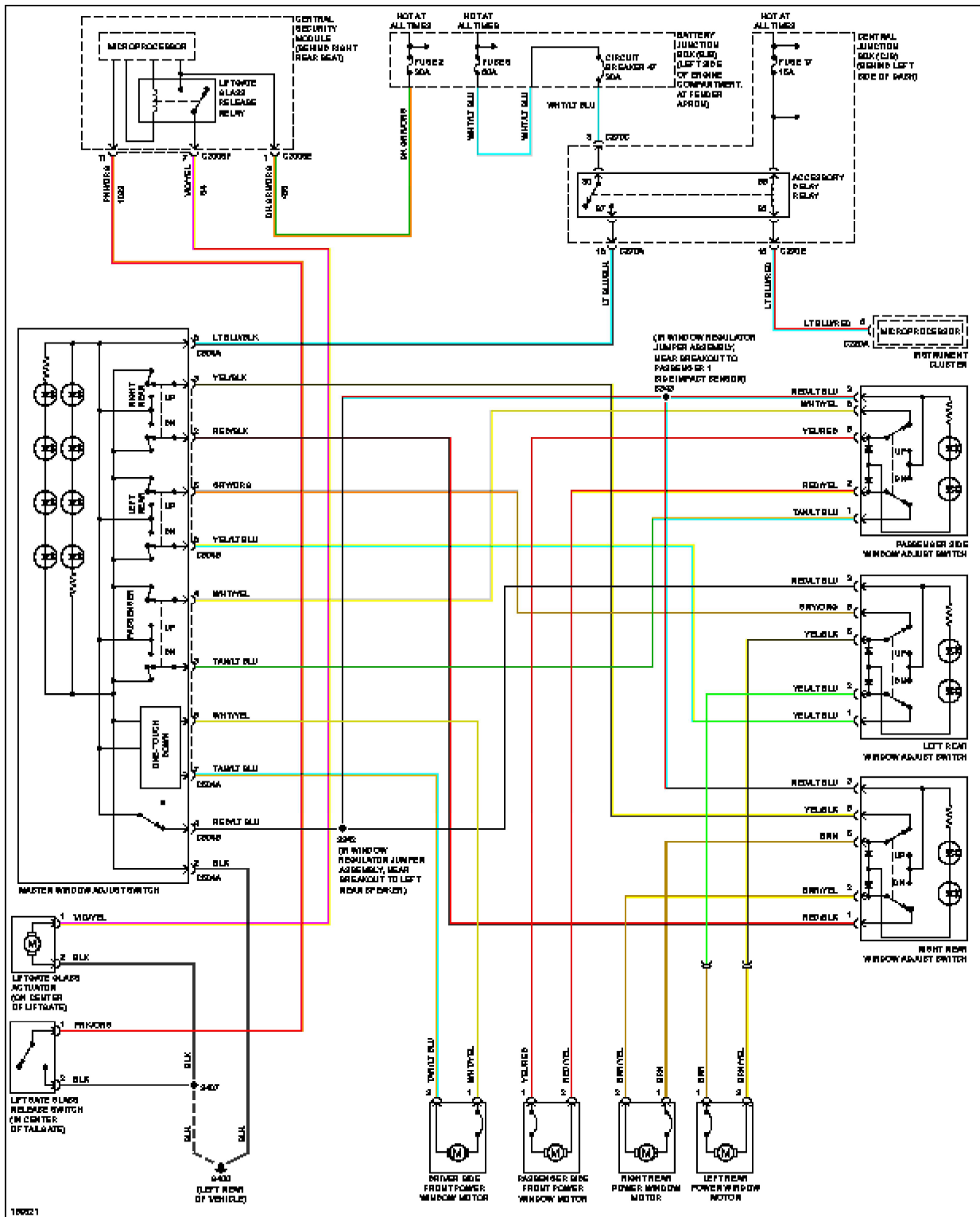

**Fig. 55: Power Top/Sunroof Circuit**

## **POWER WINDOWS**

# 2003 Ford Explorer

## SYSTEM WIRING DIAGRAMS 'Ford - Explorer



**Fig. 56: Power Windows Circuit**

## 2003 Ford Explorer

SYSTEM WIRING DIAGRAMS 'Ford - Explorer

### RADIO

# 2003 Ford Explorer

## SYSTEM WIRING DIAGRAMS 'Ford - Explorer

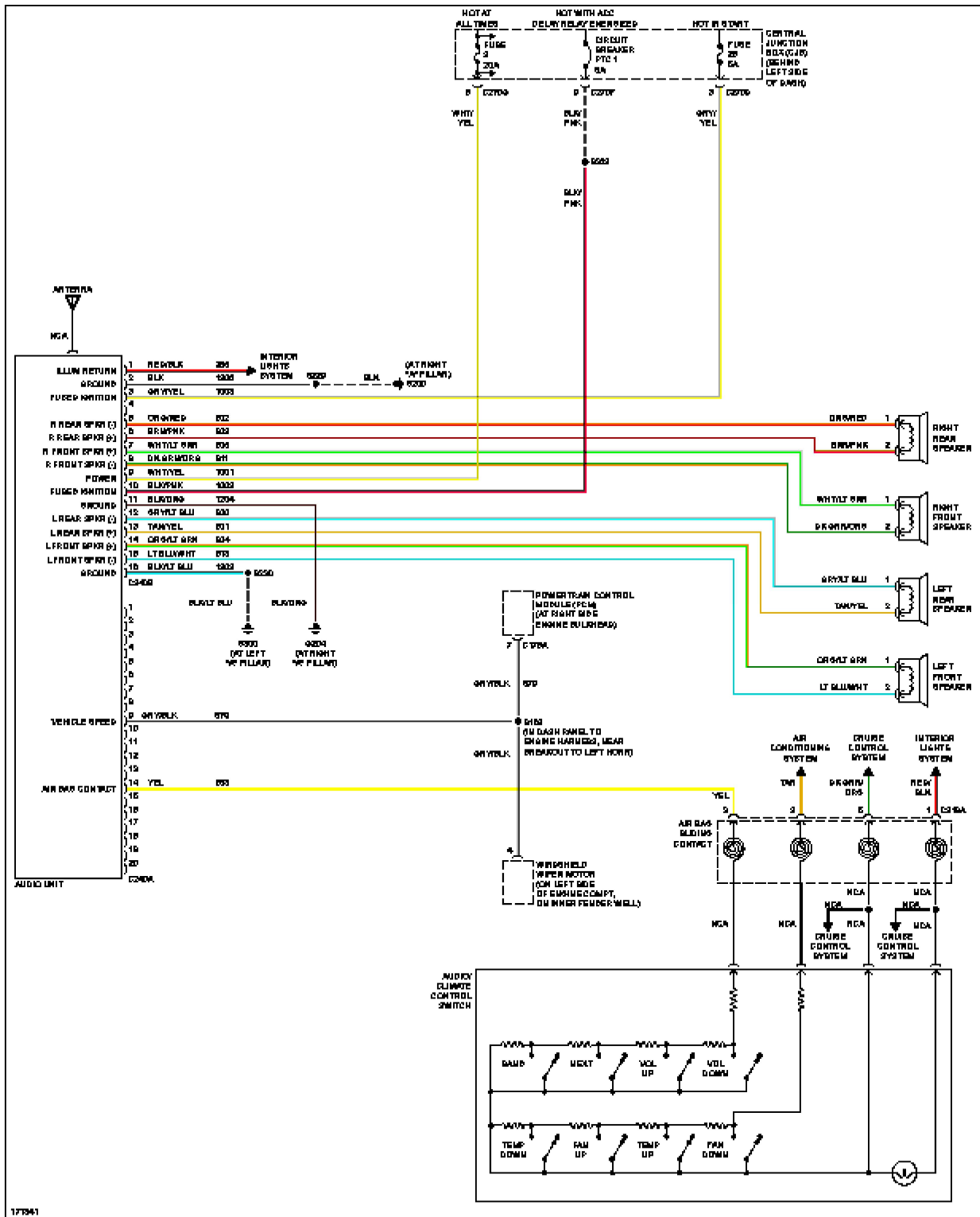
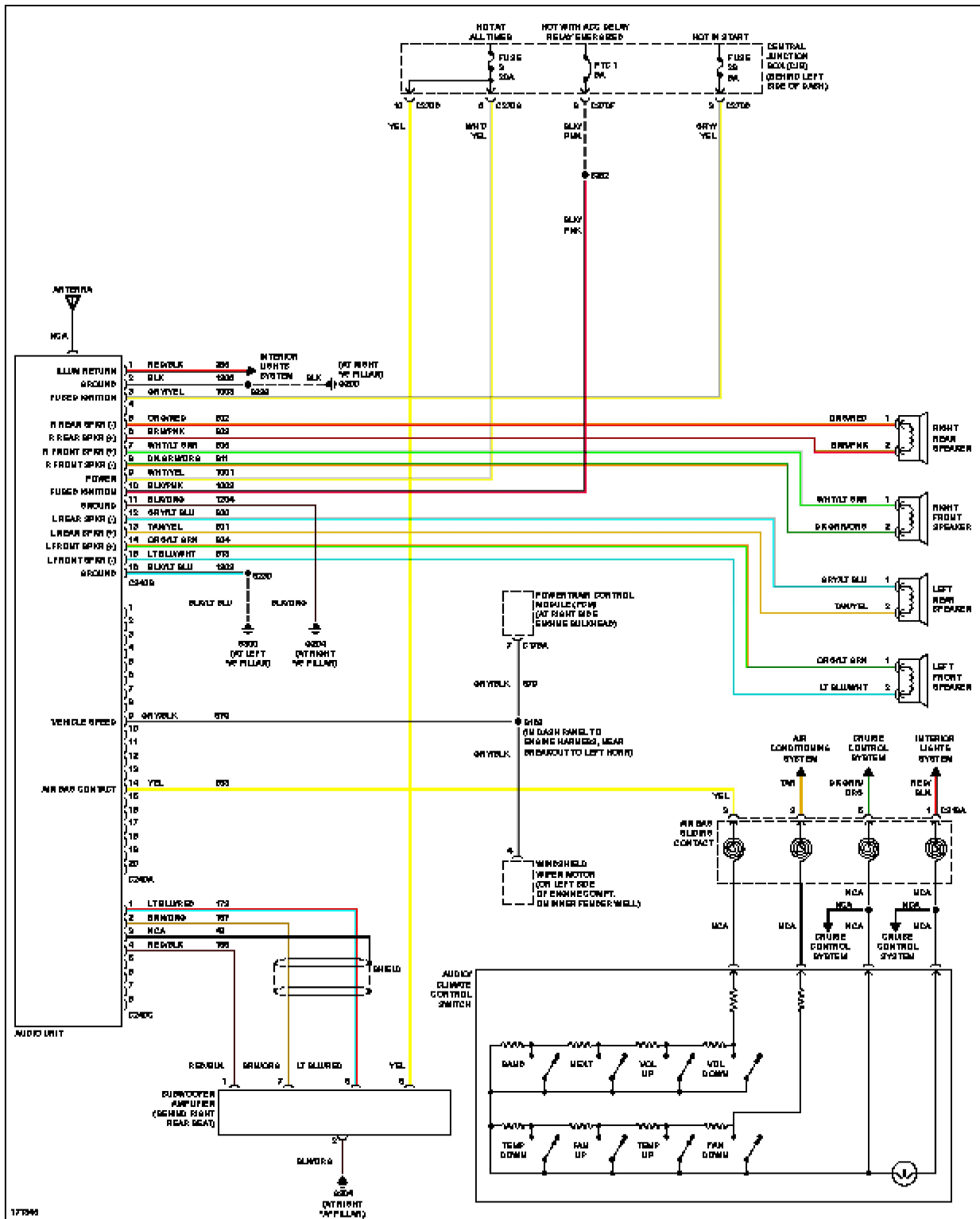

Fig. 57: Base Radio Circuit

# 2003 Ford Explorer

## SYSTEM WIRING DIAGRAMS 'Ford - Explorer



**Fig. 58: Premium Sound Radio Circuit**

# 2003 Ford Explorer

## SYSTEM WIRING DIAGRAMS 'Ford - Explorer

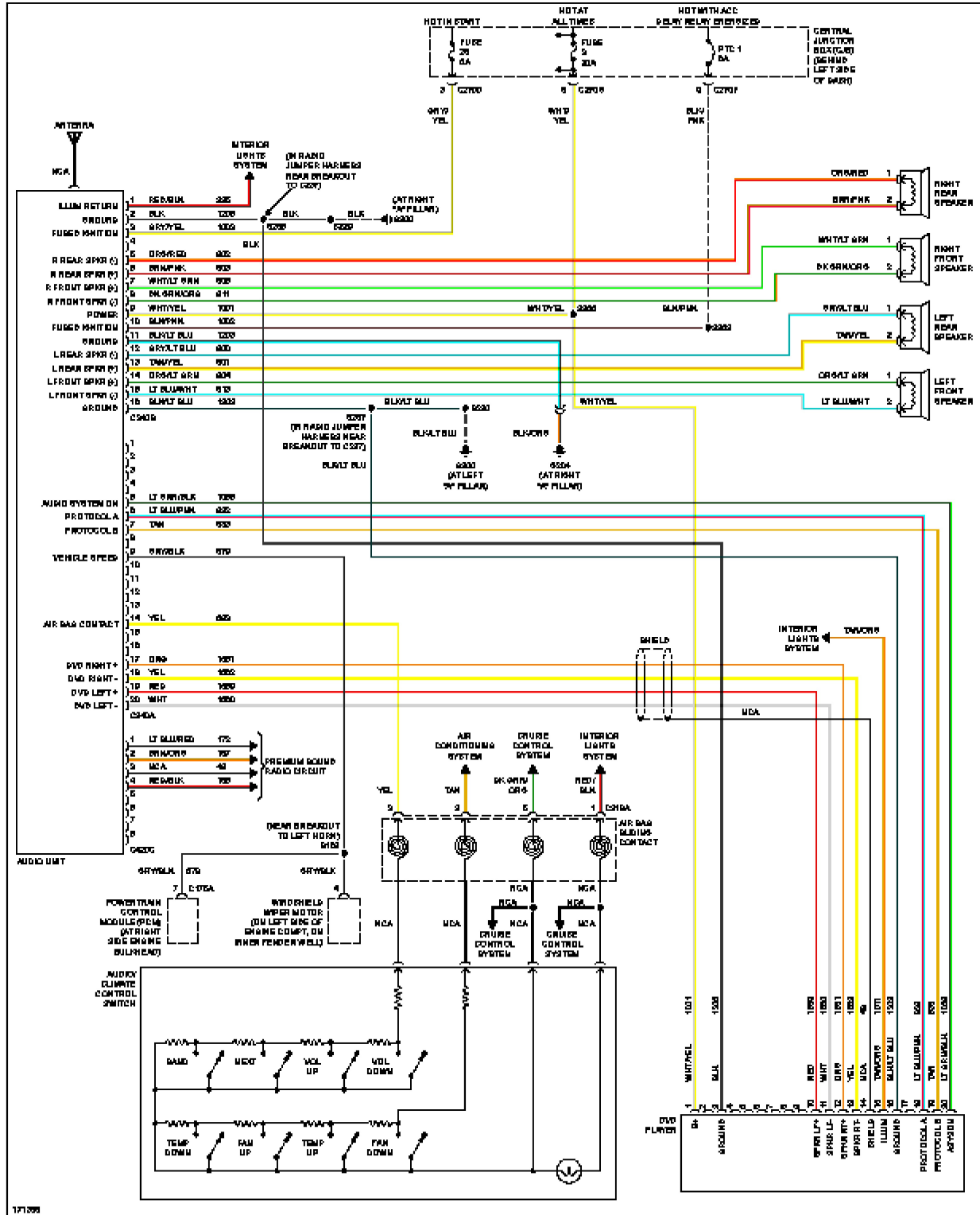

**Fig. 59: Rear Seat Entertainment Circuit**



## **SHIFT INTERLOCK**

# 2003 Ford Explorer

## SYSTEM WIRING DIAGRAMS 'Ford - Explorer

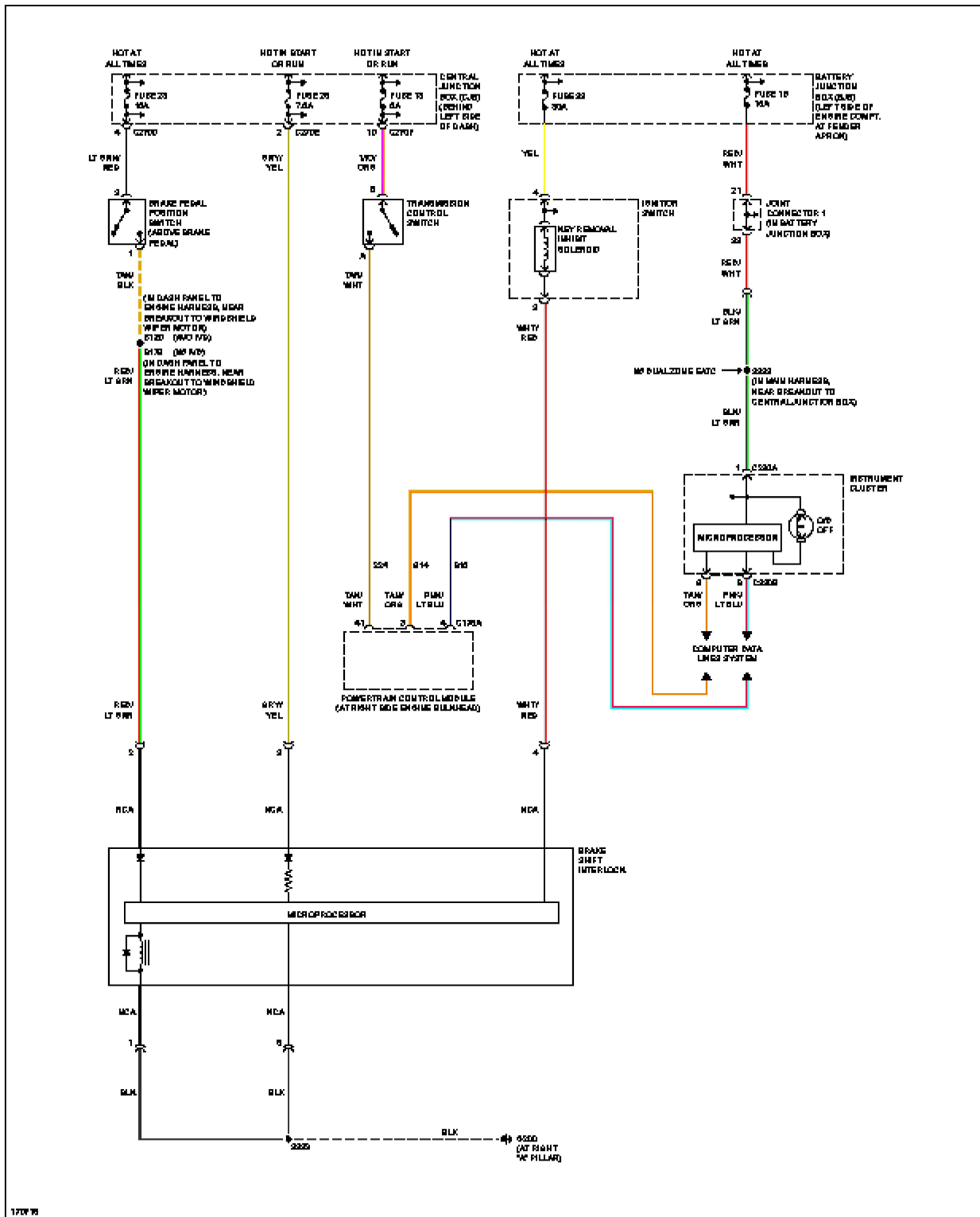
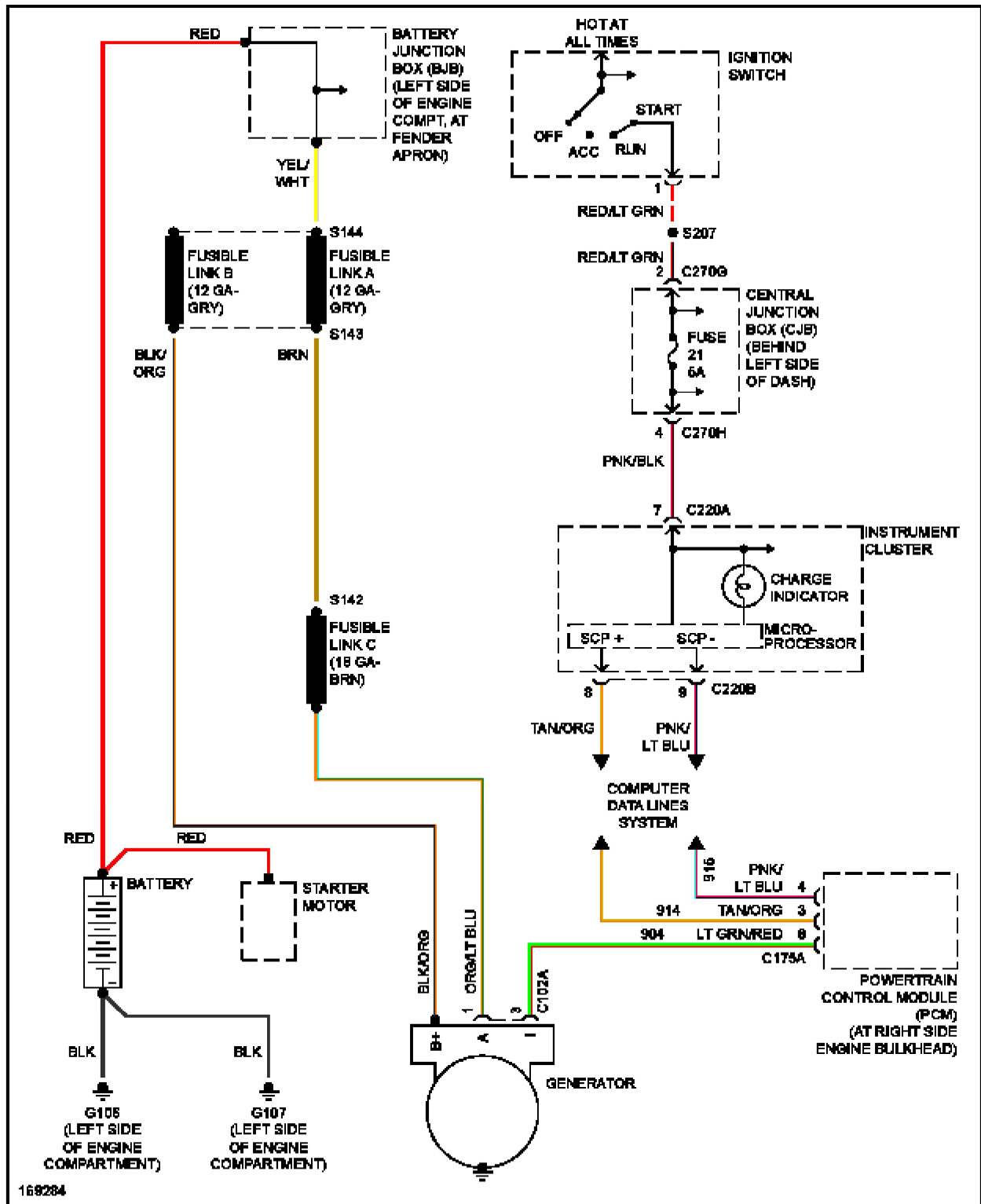

**Fig. 60: Shift Interlock Circuit**

## **STARTING/CHARGING**

# 2003 Ford Explorer

## SYSTEM WIRING DIAGRAMS 'Ford - Explorer



**Fig. 61: Charging Circuit**

# 2003 Ford Explorer

## SYSTEM WIRING DIAGRAMS 'Ford - Explorer

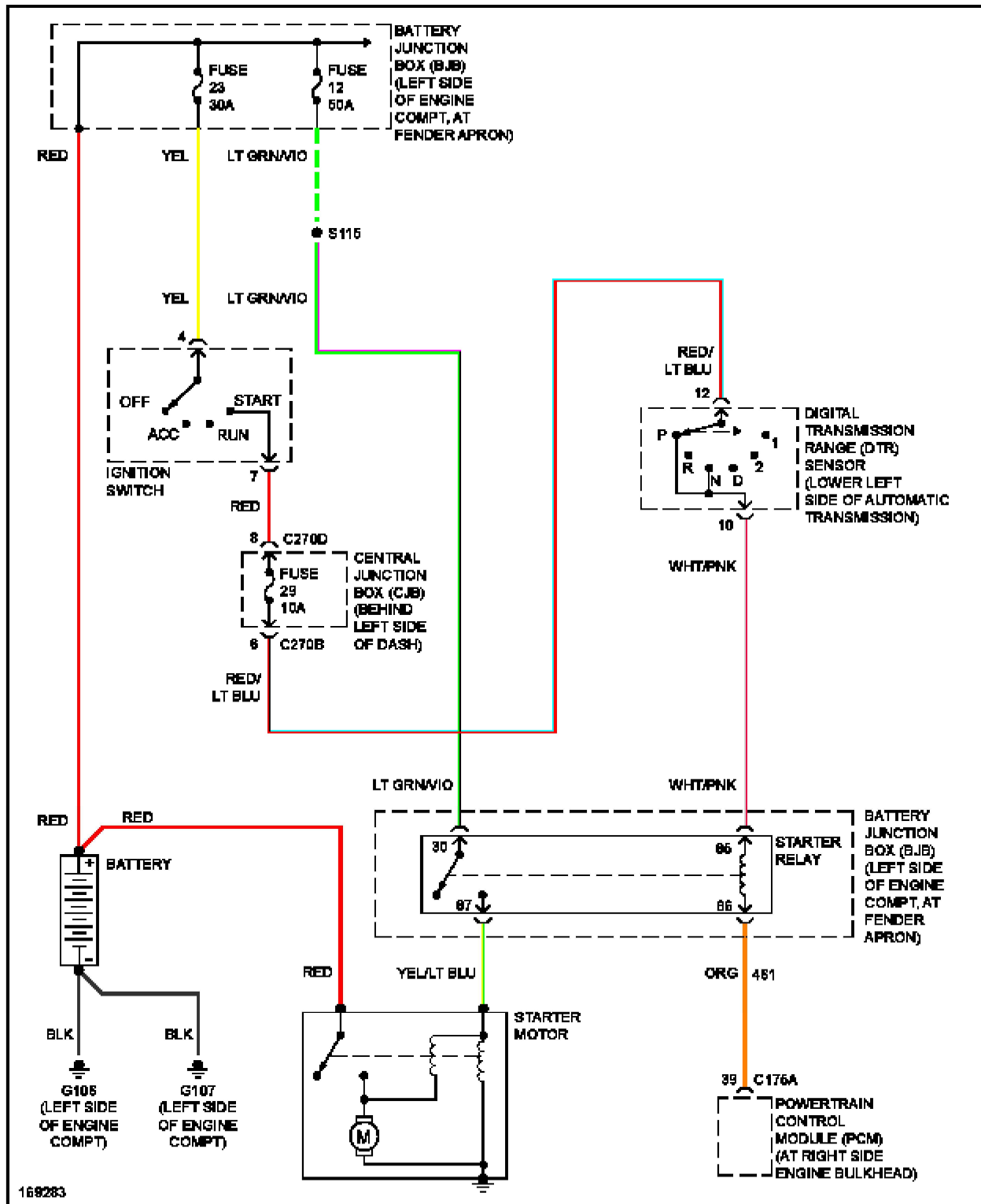

**Fig. 62: Starting Circuit**

## **SUPPLEMENTAL RESTRAINTS**

# 2003 Ford Explorer

## SYSTEM WIRING DIAGRAMS 'Ford - Explorer

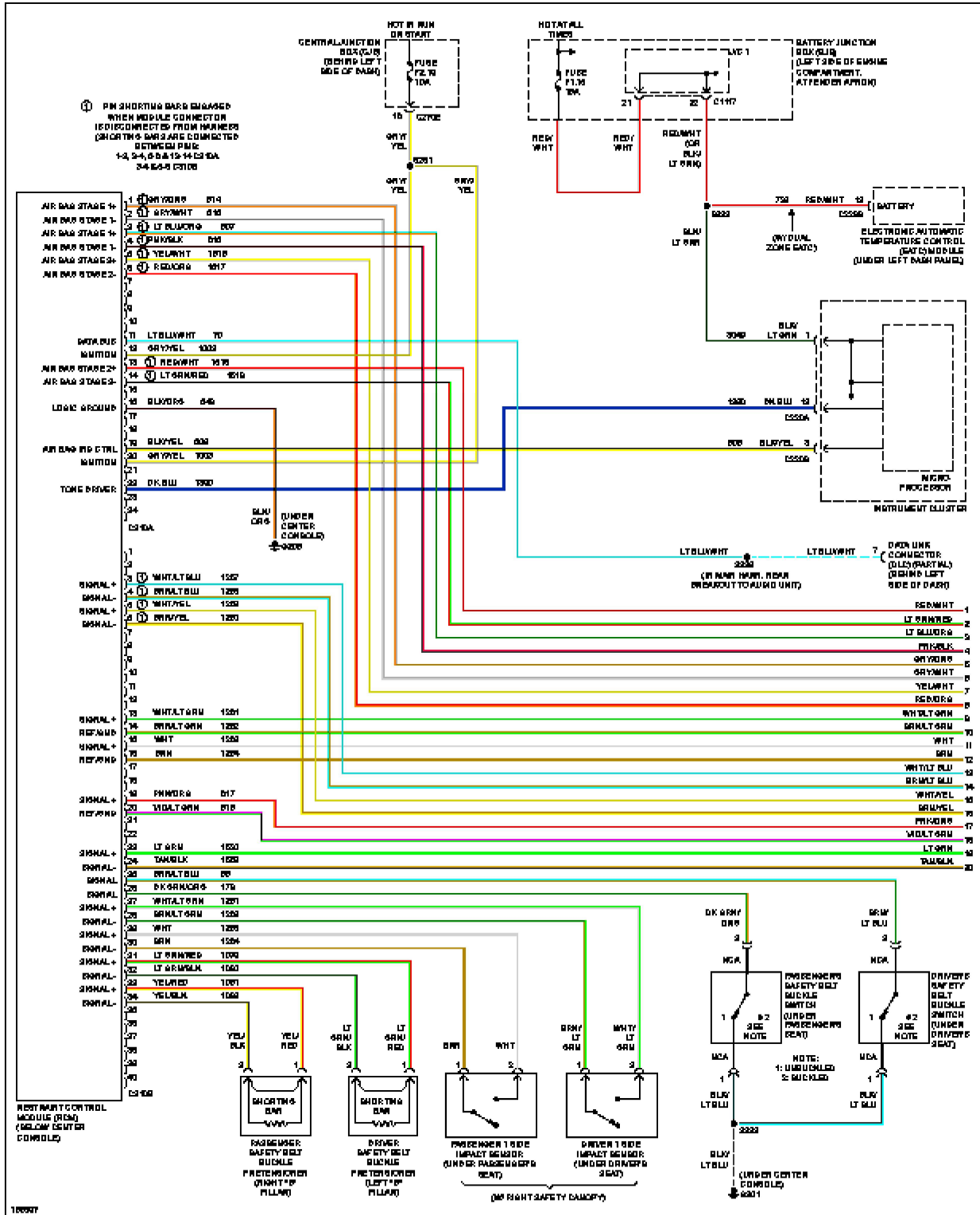
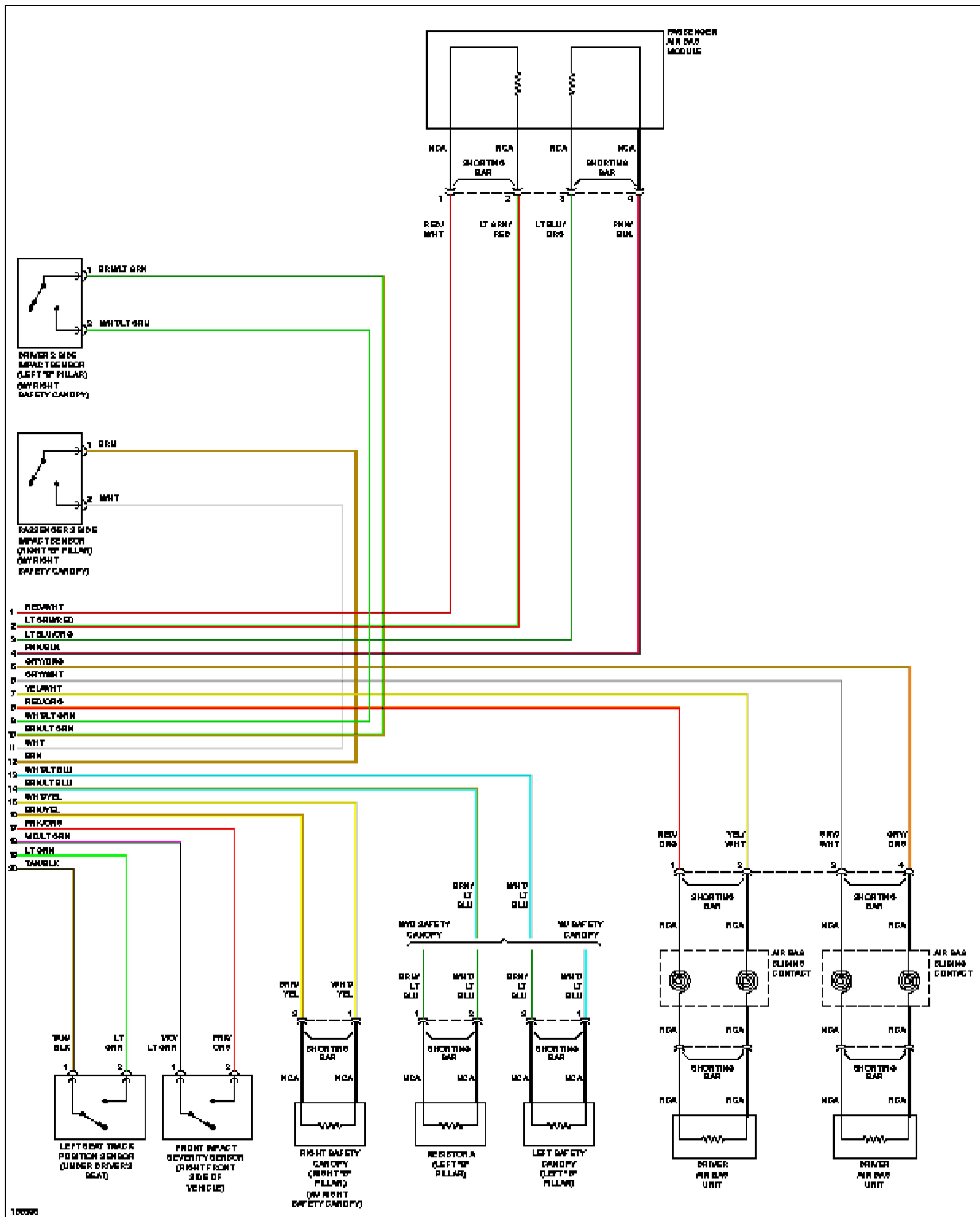

Fig. 63: Supplemental Restraints Circuit (1 of 2)

# 2003 Ford Explorer

## SYSTEM WIRING DIAGRAMS 'Ford - Explorer



**Fig. 64: Supplemental Restraints Circuit (2 of 2)**



## **TRANSMISSION**

# 2003 Ford Explorer

## SYSTEM WIRING DIAGRAMS 'Ford - Explorer

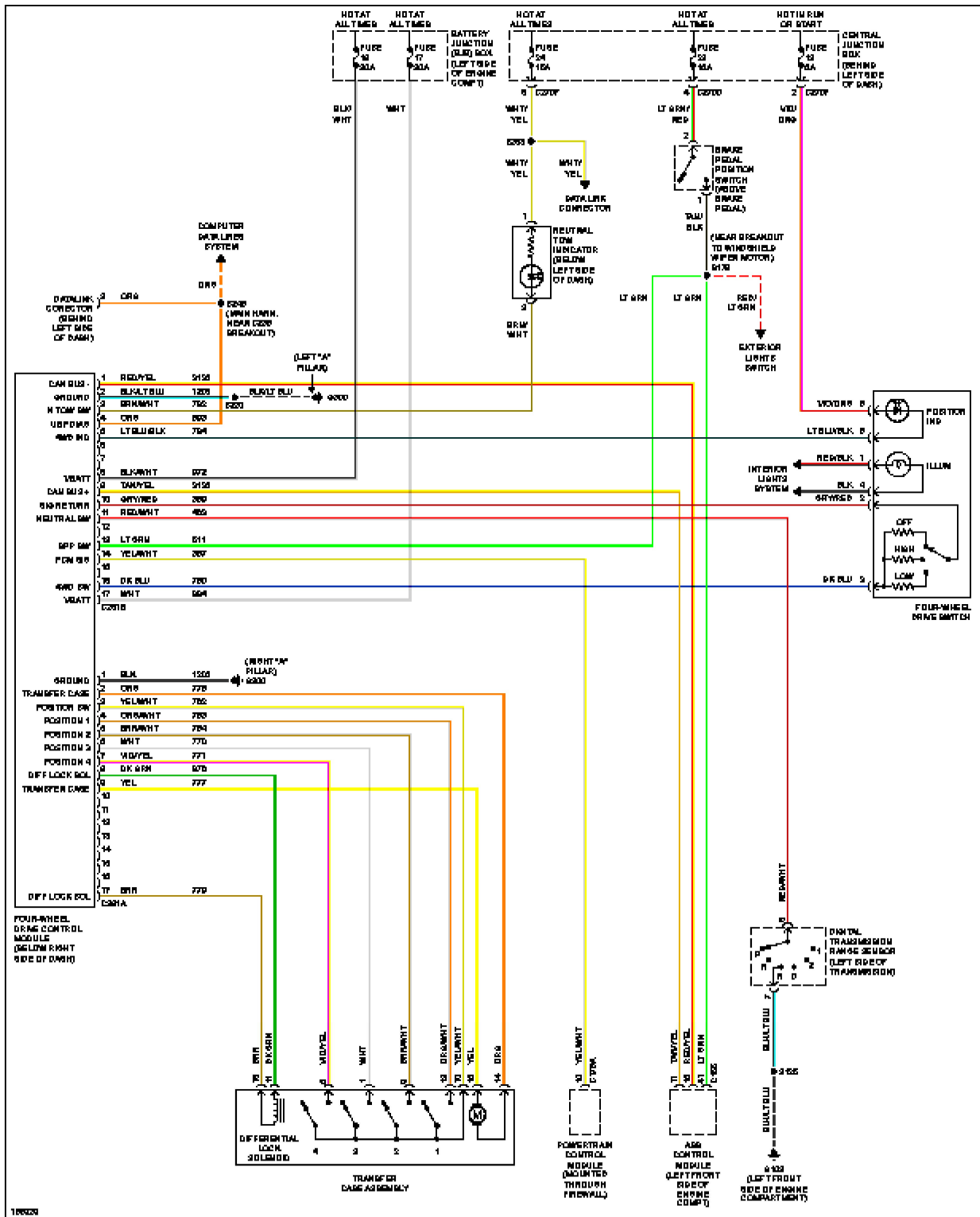

Fig. 65: 4WD Circuit, W/ Traction Control

# 2003 Ford Explorer

## SYSTEM WIRING DIAGRAMS 'Ford - Explorer

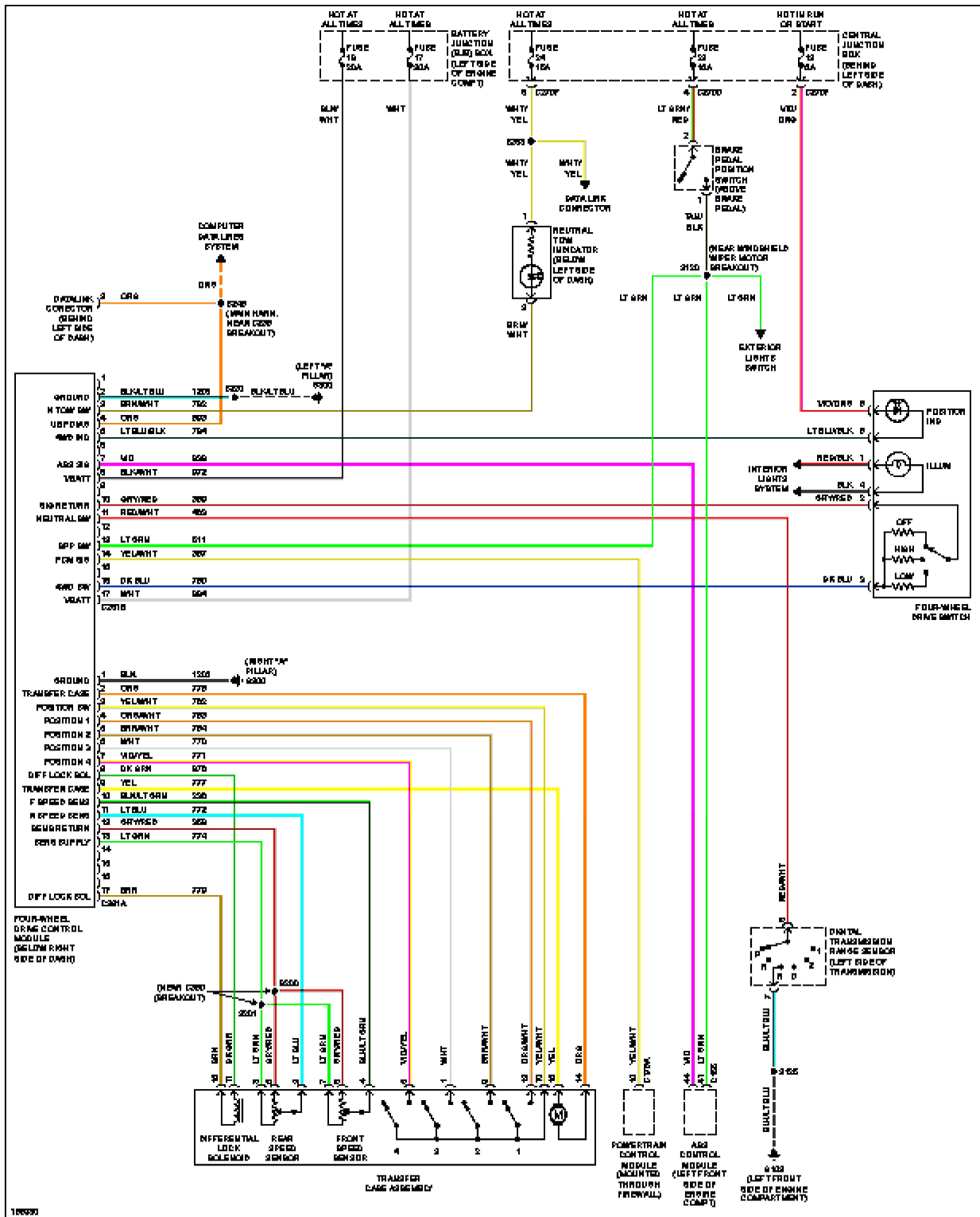

Fig. 66: 4WD Circuit, W/O Traction Control

# 2003 Ford Explorer

## SYSTEM WIRING DIAGRAMS 'Ford - Explorer

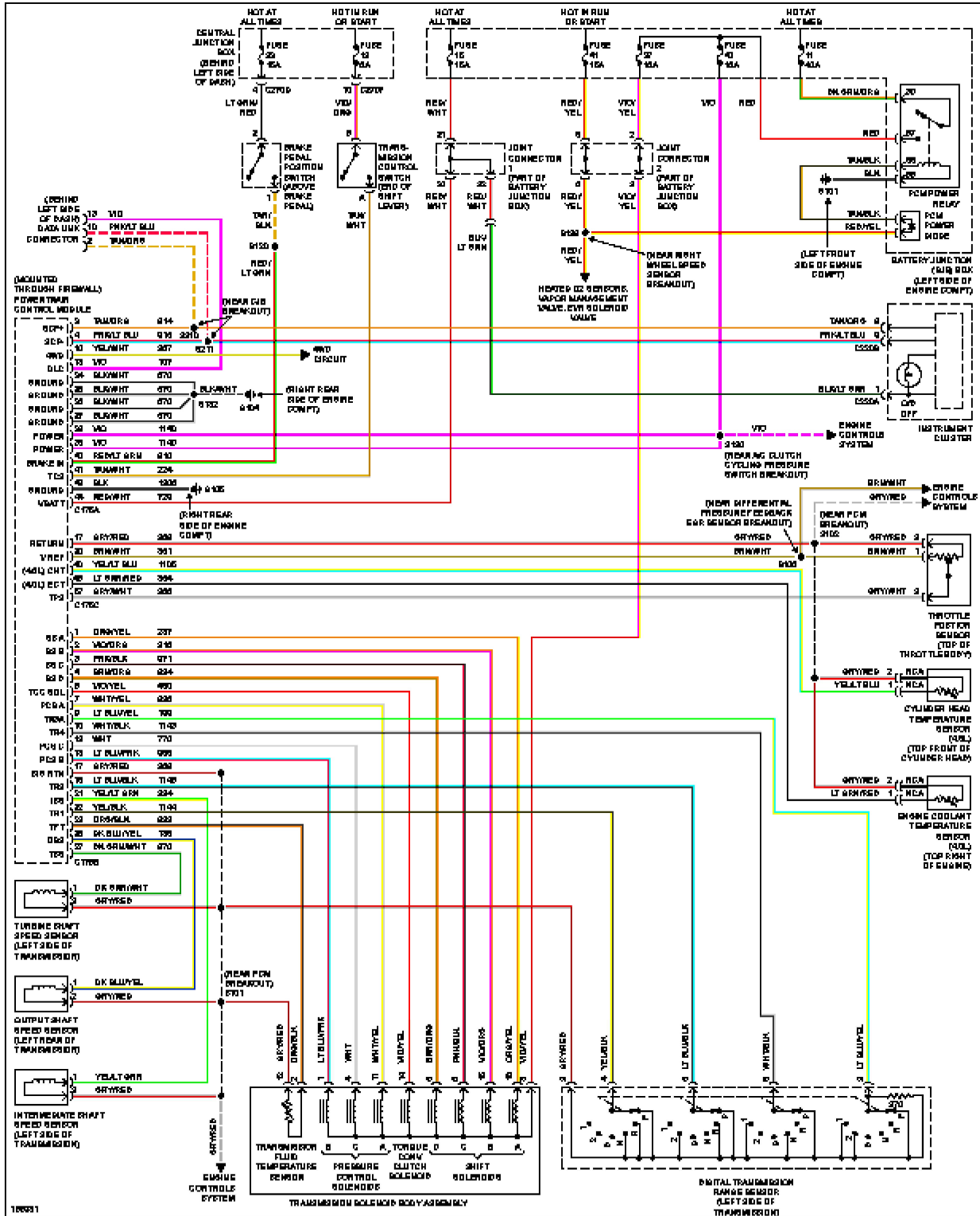
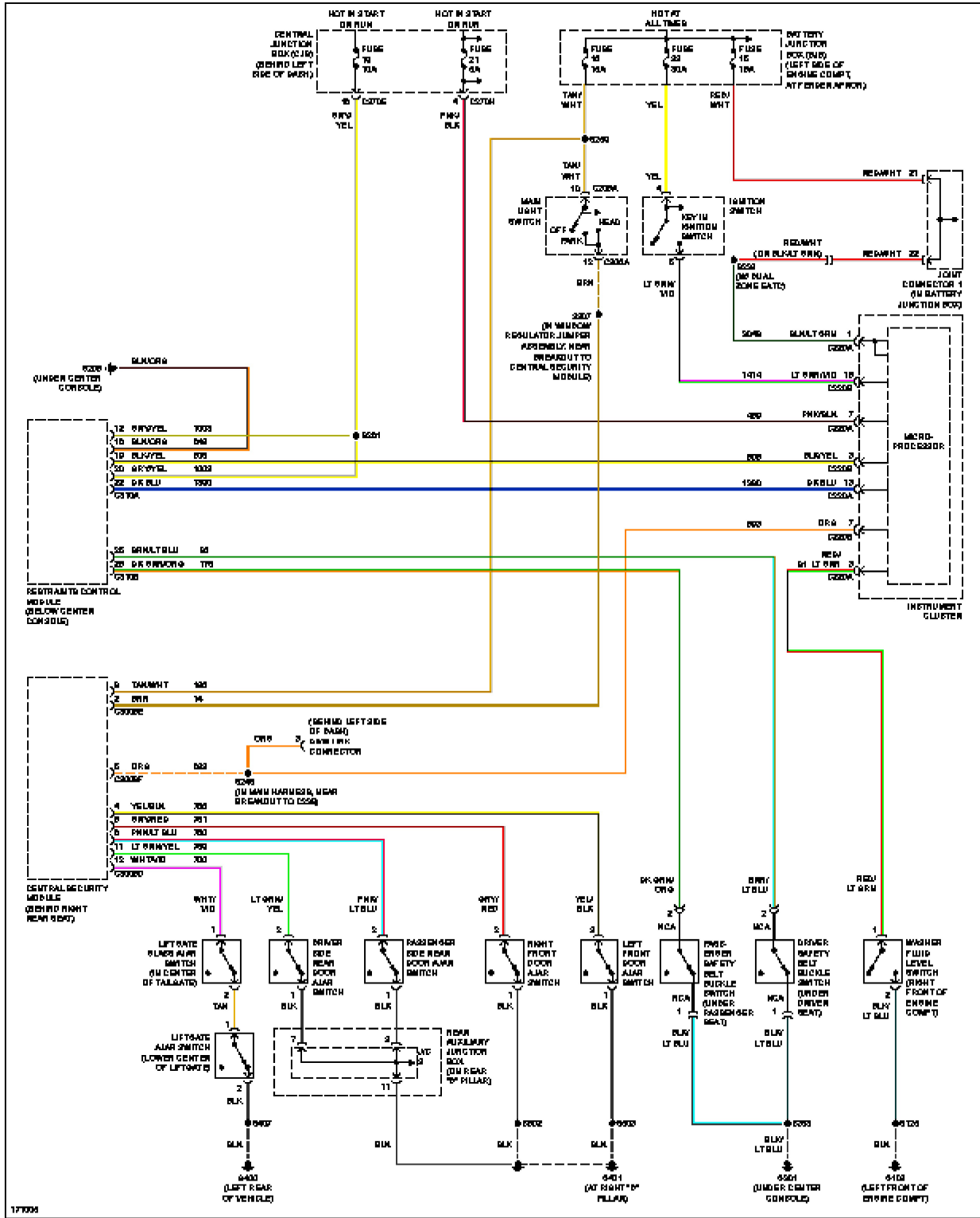

Fig. 67: A/T Circuit

## **WARNING SYSTEMS**

# 2003 Ford Explorer

## SYSTEM WIRING DIAGRAMS 'Ford - Explorer



**Fig. 68: Key Reminder & Seat Belt Warning Circuit**

# 2003 Ford Explorer

## SYSTEM WIRING DIAGRAMS 'Ford - Explorer

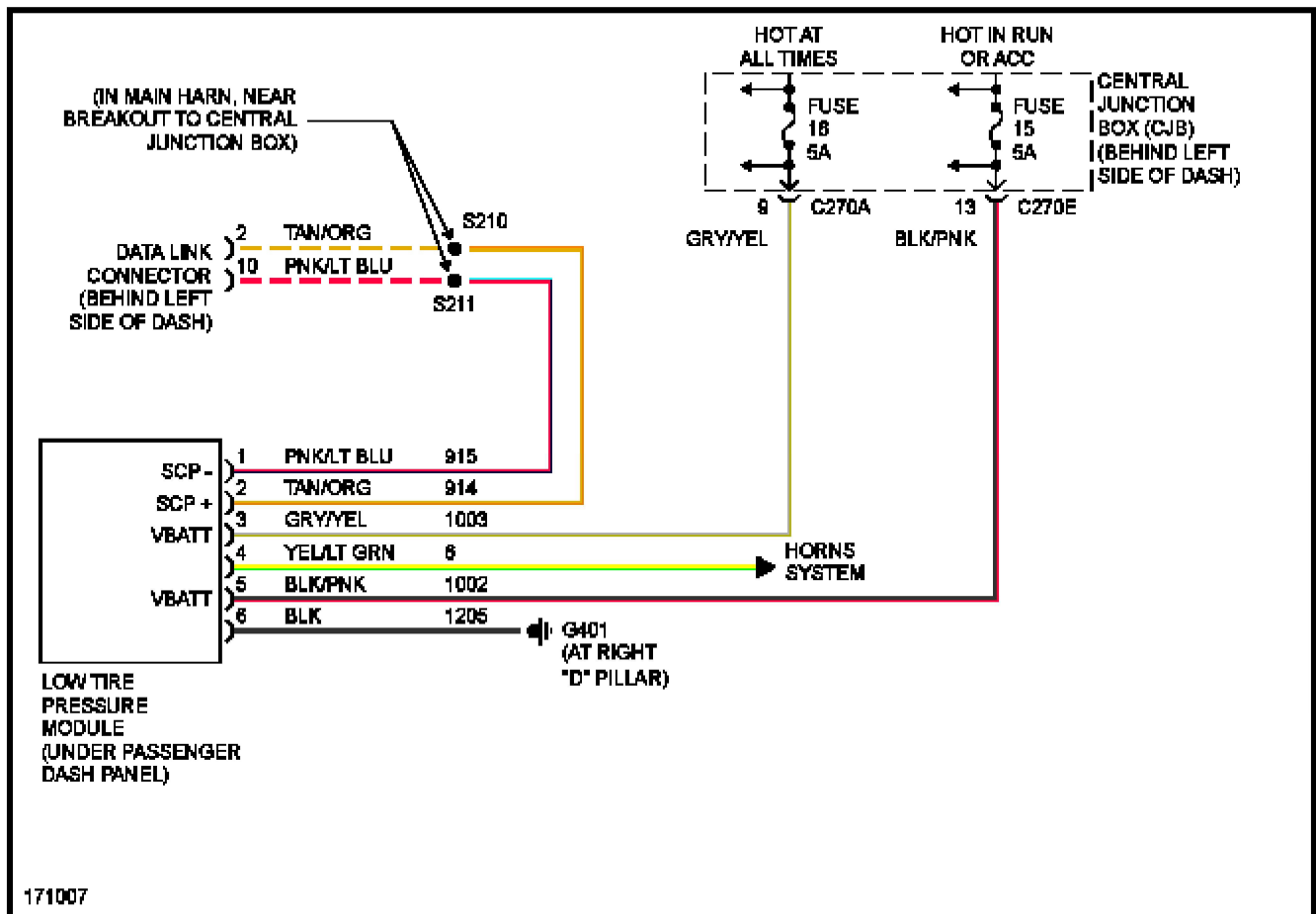

**Fig. 69: Tire Pressure Monitoring Circuit**

**2003 Ford Explorer**

SYSTEM WIRING DIAGRAMS' 'Ford - Explorer

**WIPER/WASHER**



# 2003 Ford Explorer

## SYSTEM WIRING DIAGRAMS 'Ford - Explorer

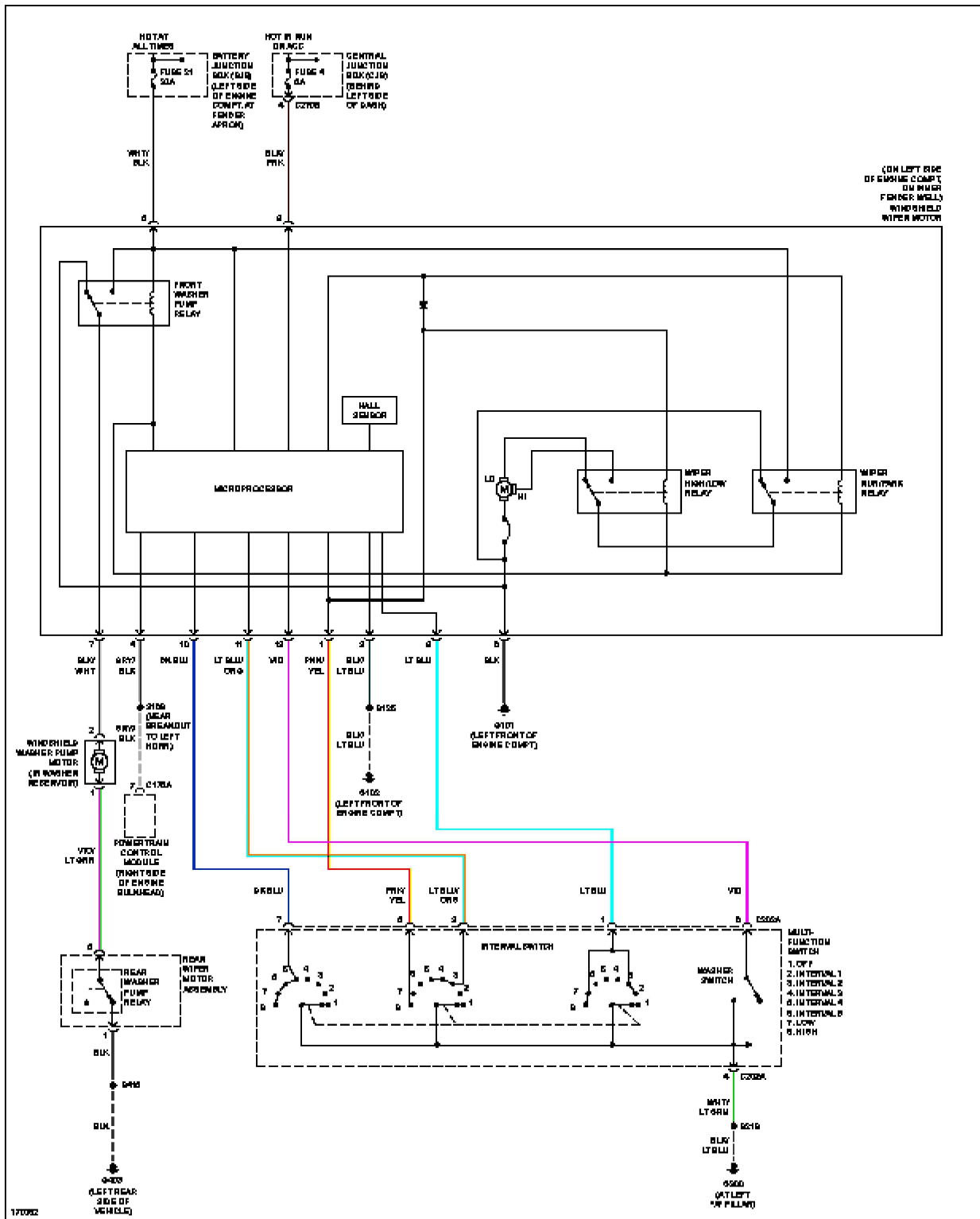

**Fig. 70: Front Wiper/Washer Circuit**

## 2003 Ford Explorer

### SYSTEM WIRING DIAGRAMS 'Ford - Explorer

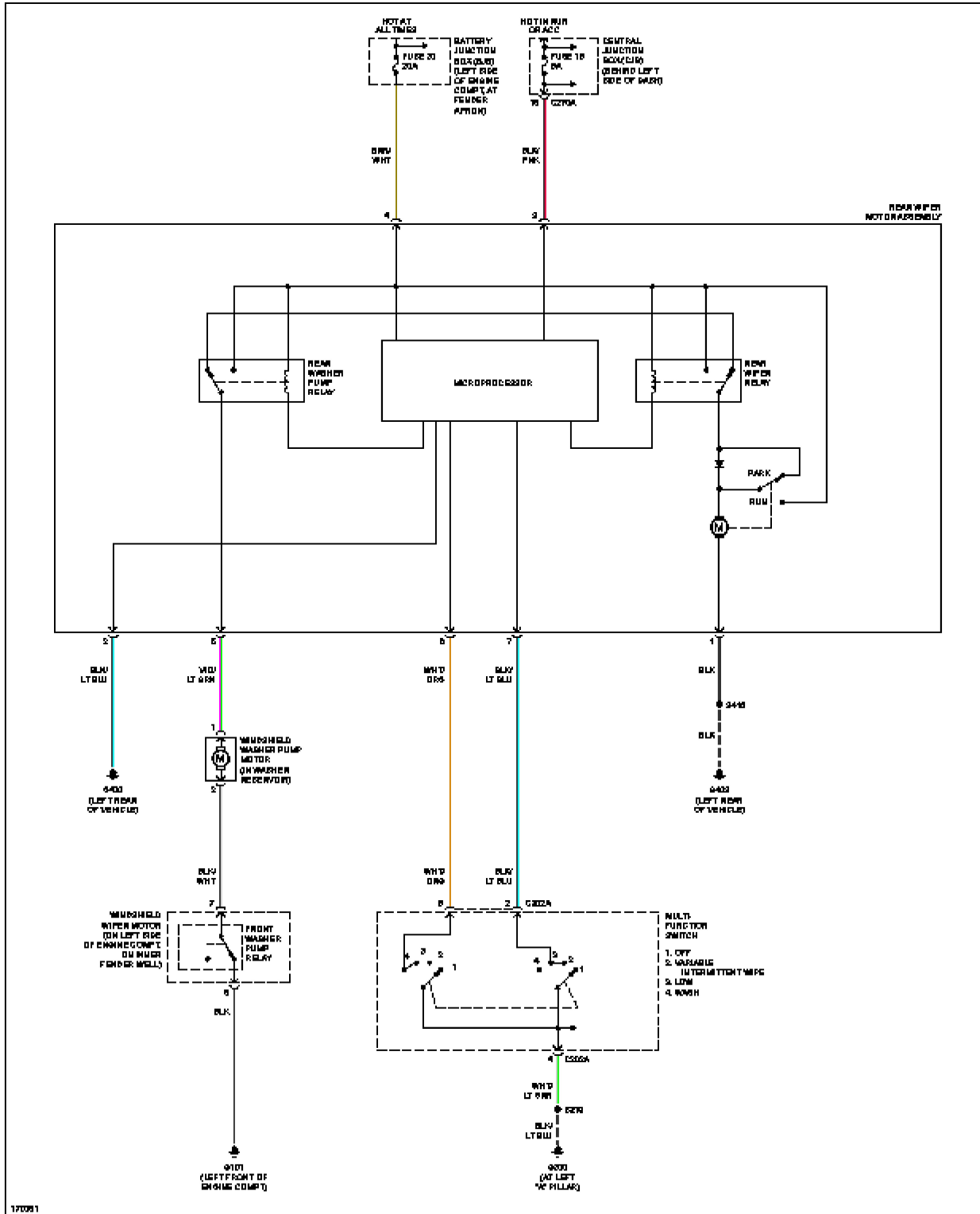

**Fig. 71: Rear Washer/Wiper Circuit**